



TECHNICAL-COMMERCIAL CATALOGUE **2023**

DEPUR ACTION *of waste* WATER



Biological treatment



Rainwater treatment



Water recovery



Hydraulics



Specific sectors



Accessories and components



BIOLOGICAL

National and European institutions' increasing attention to environmental issues calls for an overall protection program of water bodies.

A significant part of pollution derives from civil houses and residential units that lack the appropriate wastewater treatment facilities.

With the purpose of supporting a sensitive approach towards the quality of domestic discharges coming from WC (black waters), sinks and dishwashers ("blonde" waters), basins, showers and bathtubs (grey waters), DI CAMILLO SERBATOI manufactures a series of plants that enable a correct treatment of those wastewaters.

Such treatment is carried out through a biological process which is divided into various steps:



PRIMARY



- grease separator
- under-sink grease separator
- septic tank
- imhoff tank

SECONDARY



- anaerobic trickling filter
- aerobic trickling filter (top outlet)
- active sludge plant
- active sludge plant "Lagoon"
- super secondary plant

COMPLETE



- septic tank with filter
- aerobic trickling filter top outlet with sedimentation
- total oxidation plant
- biological oxidation plant
- active sludge plant with constant flow rate
- aerated biofiltration (MBBR)
- SBR

BIOSMART



- multi-compartment biological reactor

SPECIAL



- depur star
- depur superstar

BIOLOGICAL | PRIMARY TREATMENT

GREASE SEPARATOR DEG

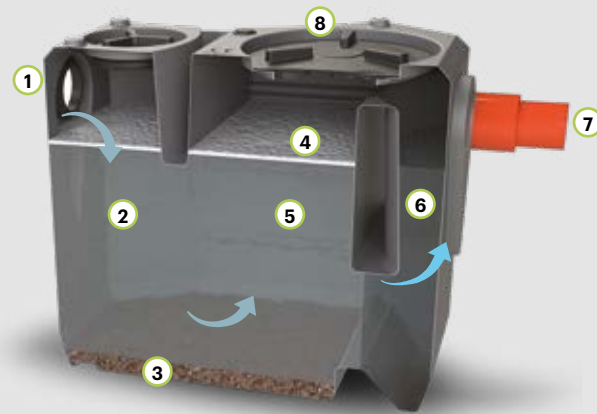

KEY

- ① Inlet pipe
- ② Flow breaker
- ③ Inerts
- ④ Oils and greases
- ⑤ Settling chamber
- ⑥ Outflow chamber
- ⑦ Outlet pipe
- ⑧ Reinforced lid (with caps and vent)

WHERE TO USE IT



INSTALLATION SCHEME

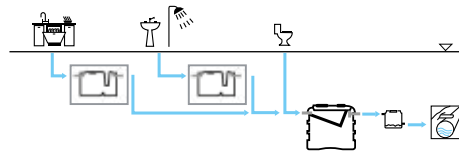

FUNCTION AND USE

The grease separator is used for the pre-treatment of waste from canteens, kitchens, soapy waters and the like. It is capable of removing clumps of floating material produced by the combination of oils-greases-detergents. The grease separator is basically a settling tank in which both the floating material that remains at the top and the sedimentable particulate matter which remains on the bottom of the tank are separated from the wastewater.

STANDARDS AND CERTIFICATIONS

T3

EN 1825-1/ 2005 e 1825-2 / 2003

CO

EN 1825-2:2003
(activities such as restaurants, canteens, etc.)

Complete the model code by typing **T3 CO** (substituting...)

TECHNICAL TABLE - PRICE LIST

icon	model	volume liters	NS	T3	CO		Le x W x h cm	he / hu cm	Ø pipe in/out mm	caps Ø cm				€
				P.E. n.	seats n.	meals/day n.				14	20	40	60	
	DEG K 120 ...	110	0,3	2	6	15	60 x 60 x 58	44 / 42	100*	-	-	1	-	260,00
	DEG K 150 ...	160	0,4	3	9	20	60 x 60 x 74	60 / 58	100*	-	-	1	-	340,00
	DEG K 200 ...	210	0,5	4	12	25	70 x 90 x 63	49 / 47	125*	-	1	1	-	420,00
	DEG L 300 ...	250	0,7	5	15	35	80 x 80 x 72	56 / 54	125	-	-	1	-	355,00
	DEG K 250 ...	260	0,8	5	15	40	70 x 90 x 72	57 / 55	125*	-	1	1	-	445,00
	DEG K 300 ...	320	1,0	6	18	50	70 x 90 x 80	66 / 64	125*	-	1	1	-	460,00
	DEG L 400 ...	350	1,0	7	20	50	80 x 80 x 94	78 / 76	125	-	-	1	-	435,00
	DEG K 400 ...	400	1,2	8	24	60	80 x 120 x 66	55 / 53	125*	1	-	1	-	555,00
	DEG L 500 ...	450	1,5	9	25	75	80 x 80 x 116	99 / 97	125	-	-	1	-	510,00
	DEG K 500 ...	500	1,5	10	30	75	80 x 120 x 76	65 / 62	125*	1	-	1	-	630,00
	DEG C 800 ...	840	2,0	16	45	100	130 x 130 x 97	78 / 76	125	-	1	1	-	780,00
	DEG C 1.200 ...	1.180	3,0	23	65	150	130 x 130 x 128	108 / 106	125	-	1	1	-	1.110,00
	DEG C 1.400 ...	1.500	3,5	30	90	175	130 x 130 x 150	131 / 129	125	-	1	1	-	1.260,00
	DEG C 1.600 ...	1.680	4,0	33	95	200	130 x 130 x 172	153 / 151	125	-	1	1	-	1.305,00
	DEG C 2.000 ...	1.920	5,0	38	100	250	130 x 130 x 194	175 / 173	125	-	1	1	-	1.455,00
	DEG CX 2100 ...	2.100	5,5	42	120	280	150 x 150 x 160	137 / 135	125	-	1	1	-	1.950,00
	DEG CX 2600 ...	2.600	6,0	52	150	300	150 x 150 x 182	159 / 157	125	-	1	1	-	2.265,00
	DEG CS 3.000 ...	3.020	6,5	60	180	330	165 x 165 x 173	155 / 152	160	-	1	1	-	2.655,00
	DEG CS 3.500 ...	3.500	7,0	70	200	350	165 x 165 x 196	175 / 172	160	-	1	1	-	2.985,00
	DEG CS 4.000 ...	4.000	8,0	80	240	400	195 x 195 x 157	130 / 127	160	-	-	2	-	3.345,00
	DEG CS 4.500 ...	4.500	9,0	90	270	450	195 x 195 x 178	153 / 150	160	-	-	2	-	3.675,00
	DEG CS 5.100 ...	5.100	10,0	100	300	500	195 x 195 x 199	172 / 169	160	-	-	2	-	3.915,00
	DEG CR 5600 ...	5.600	11,0	110	330	550	230 x 230 x 188	155 / 153	200	-	-	2	-	4.455,00
	DEG CR 7000 ...	7.000	14,5	140	400	740	230 x 230 x 218	181 / 179	200	-	-	2	-	4.980,00
	DEG N 9000 ...	7.520	15,0	150	450	750	285 x 210 x 234	195 / 192	200	-	1	-	1	5.670,00
	DEG M 12000 ...	11.880	24,0	235	700	1.200	440 x 210 x 234	206 / 201	200	-	-	-	2	10.080,00
	DEG MN 15000 ...	13.360	30,0	265	800	1.500	465 x 210 x 234	195 / 192	200	-	-	-	2	11.500,00
	DEG M 18000 ...	17.650	36,0	350	1.000	1.800	620 x 210 x 234	206 / 201	200	-	-	-	2	14.490,00
	DEG MN 21000 ...	19.130	42,0	380	1.200	2.100	645 x 210 x 234	195 / 192	200	-	-	-	2	16.380,00
	DEG M 24000 ...	23.420	48,0	465	1.400	2.400	800 x 210 x 234	206 / 201	200	-	-	-	2	18.430,00
	DEG M 30000 ...	29.220	54,0	580	1.700	2.700	980 x 210 x 234	206 / 201	200	-	-	-	2	21.735,00
	DEG M 36000 ...	35.060	60,0	700	2.000	3.000	1.160 x 210 x 234	206 / 201	200	-	-	-	2	26.460,00

* IN (only gasket) / OUT (male pipe)

BIOLOGICAL | PRIMARY TREATMENT

UNDER-SINK GREASE SEPARATOR DEG SL



KEY

- ① Inlet
- ② Settling chamber
- ③ Oils and greases
- ④ Inerts
- ⑤ Outflow chamber
- ⑥ Outlet
- ⑦ Threaded cap Ø 200 PP with vent

WHERE TO USE IT



INSTALLATION SCHEME

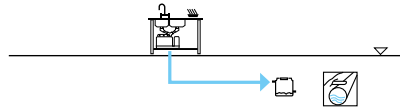

FUNCTION AND USE

Domestic grease separator made of polyethylene to be installed under a regular sink, with the purpose of treating wastewater which, before reaching the public sewer, will be deprived from floating substances such as greases, animal/vegetal oils as well as solid substances such as sand and inerts.

Its functioning is based on a very simple principle: oils and greases, thanks to their specific weight, remain trapped inside the container thanks to the presence of special weirs and siphons inside the tank. For its installation, the sink drain pipe must be inserted into the inlet that is positioned on the upper part of the separator and the outlet must be connected to the discharge. A threaded cap installed on the structure allows its inspection and maintenance, which consists in removing the oils after a weekly check of the state of the deposit visible on the upper part of the tank. Oil layer must not exceed 10 cm height.

STANDARDS AND CERTIFICATIONS

EN 1825-1/2

DegSink

UNDER-SINK
GREASE SEPARATOR







- Space saver
- Fits all kitchen types
- Easy installation
- Blocks greases
- Keeps your house drains clean
- Easy maintenance
- Pump for greases disposal
- Compliant with standards
- Environmentally friendly

TECHNICAL TABLE - PRICE LIST

icon	model	volume liters	NS	Le x W x h cm	he / hu cm	Ø pipe in/out mm	caps Ø cm n.	greases		inerts		packaging	€
								volume liters	h mm	volume liters	h mm		
	DEG SL 20 T3 PS	18	0,1	36 x 23 x 30	27 / 23	32	200	4	6	10	14	37x24x31	110,00

ACCESSORIES TABLE

icon	model	description	technical characteristics	€
	MEN DEG	under-sink support shelf	Le 54 x W 23,5 x h 30 cm	100,00
	POM DEG	grease suction pump	max 5 litres	20,00
	KTUB DEG	flexible pipes kit + fittings for adjustment to the discharge		70,00
	STARSINK	biological activator	n. 1 pack with 20 sticks (1 stick per week is recommended)	20,00

ACCESSORIES

COD. MEN DEG



COD. POM DEG



COD. KTUB DEG



COD. STARSINK



APPLICATION



PACKAGING



BIOLOGICAL | PRIMARY TREATMENT

SEPTIC TANK SET

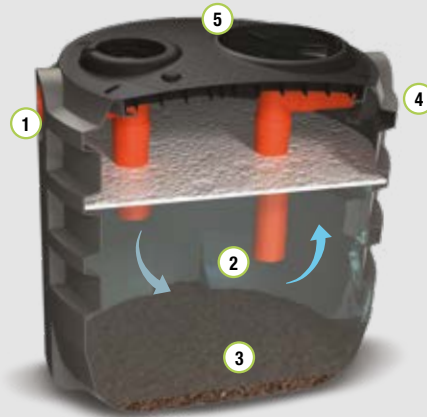

KEY

- ① Inlet pipe
- ② Settling chamber
- ③ Sedimented sludge digestion
- ④ Outlet pipe
- ⑤ Reinforced lid (with caps and vent)

WHERE TO USE IT



INSTALLATION SCHEME

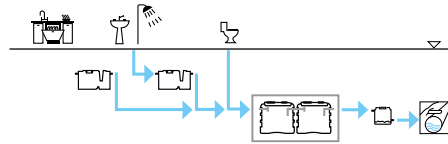

FUNCTION AND USE

The septic tank is generally used as the primary treatment of black wastewater from residential buildings or similar drains. Upstream of it, it is advisable to place a grease separator with the aim of eliminating the oils and greases present in the sewage arriving at the tank.

It is a settling tank with the function of favoring the sedimentation of the fine particles present inside the sewage to be treated, which remain on the bottom of the tank and, through the anaerobic digestion, to break down an aliquot of BOD_5 .

STANDARDS AND CERTIFICATIONS

EN 12566-1

SM

one-chamber
septic tank

SB





















two-chamber
septic tank

ST

three-chamber
septic tank

Complete the model code by typing **SM SB ST** (substituting ...)

TECHNICAL TABLE - PRICE LIST

icon	model	volume* liters	SM	SB	ST	Le x W x h cm	he / hu cm	Ø pipe in/out mm	caps Ø cm			price list SM €	price list SB €	price list ST €
			P.E.	P.E.	P.E.				20	40	60			
			n.	n.	n.				n.					
	SET L 500 ...	450	3	6	9	80 x 80 x 116	99 / 97	125	-	1	-	505,00	1.010,00	1.620,00
	SET C 800 ...	840	6	12	18	130 x 130 x 97	78 / 76	125	1	1	-	745,00	1.485,00	2.230,00
	SET C 1200 ...	1.180	8	16	25	130 x 130 x 128	108 / 106	125	1	1	-	945,00	1.890,00	2.835,00
	SET C 1400 ...	1.500	10	21	32	130 x 130 x 150	131 / 129	125	1	1	-	1.070,00	2.140,00	3.210,00
	SET C 1600 ...	1.680	12	24	36	130 x 130 x 172	153 / 151	125	1	1	-	1.185,00	2.520,00	3.780,00
	SET C 2000 ...	1.920	14	27	41	130 x 130 x 194	175 / 173	125	1	1	-	1.425,00	2.905,00	4.350,00
	SET CX 2100 ...	2.100	15	30	45	150 x 150 x 160	137 / 135	125	1	1	-	1.500,00	3.310,00	4.965,00
	SET CX 2600 ...	2.600	18	37	55	150 x 150 x 182	159 / 157	125	1	1	-	1.860,00	4.255,00	6.385,00
	SET CS 3000 ...	3.020	21	43	65	165 x 165 x 173	155 / 152	160	1	1	-	2.295,00	4.590,00	6.885,00
	SET CS 3500 ...	3.500	25	50	75	165 x 165 x 196	175 / 172	160	1	1	-	2.605,00	5.200,00	7.800,00
	SET CS 4000 ...	4.000	28	57	85	195 x 195 x 157	130 / 127	160	-	2	-	3.150,00	6.460,00	9.690,00
	SET CS 4500 ...	4.500	32	64	96	195 x 195 x 178	153 / 150	160	-	2	-	3.285,00	7.090,00	10.635,00
	SET CS 5100 ...	5.100	36	72	110	195 x 195 x 199	172 / 169	160	-	2	-	3.780,00	7.560,00	11.340,00
	SET CR 5600 ...	5.600	40	80	120	230 x 230 x 188	155 / 153	160	-	2	-	3.915,00	7.830,00	11.745,00
	SET CR 7000 ...	7.000	50	100	150	230 x 230 x 218	181 / 179	160	-	2	-	4.890,00	9.780,00	14.670,00
	SET N 9000 ...	7.520	54	-	-	285 x 210 x 234	195 / 192	160	1	-	1	5.125,00	-	-
	SET M 12000 SM	11.880	85	-	-	440 x 210 x 234	206 / 201	160	-	-	2	9.295,00	-	-
	SET MN 15000 SM	13.360	95	-	-	465 x 210 x 234	195 / 192	160	-	-	2	11.500,00	-	-
	SET M 18000 SM	17.650	126	-	-	620 x 210 x 234	206 / 201	160	-	-	3	14.490,00	-	-
	SET M 24000 SB	23.420	-	167	-	800 x 210 x 234	206 / 201	160	-	-	4	-	18.900,00	-
	SET M 36000 ST	35.060	-	-	250	1.160 x 210 x 234	206 / 201	160	-	-	6	-	-	30.870,00

* one chamber

BIOLOGICAL | PRIMARY TREATMENT

IMHOFF TANK IMF

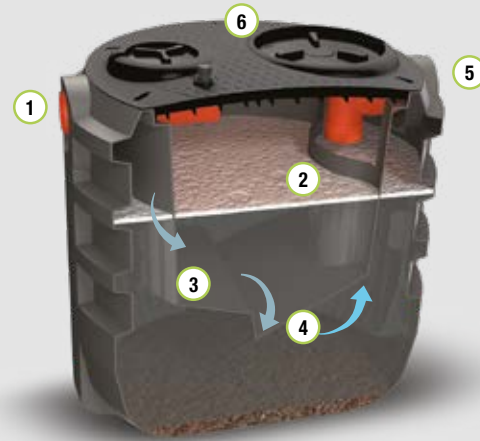

KEY

- ① Inlet pipe
- ② Settling tank
- ③ Organic substances digestion
- ④ Sedimented sludge
- ⑤ Outlet pipe
- ⑥ Reinforced lid (with caps and vent)

WHERE TO USE IT



INSTALLATION SCHEME

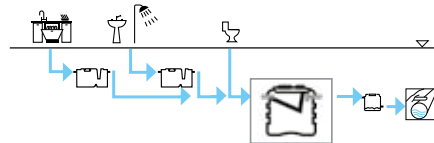

FUNCTION AND USE

The Imhoff tank is a tank with the function of favoring the sedimentation of the coarse solids present inside the sewage which remain on the bottom of the tank and, through the anaerobic digestion, to break down an aliquot of BOD_5 . It is made up of two hydraulically communicating compartments, the first for sedimentation and the second for digestion of organic substances.

STANDARDS AND CERTIFICATIONS

DS

EN 12566-1
semestral spurge

NR

EN 12566-1
annual spurge

TECHNICAL TABLE - PRICE LIST

icon	model	volume liters	DS	NR	Le x W x h cm	he / hu cm	Ø pipe in/out mm	caps Ø cm			€
			P.E. n.	P.E. n.				20	40	60	
	IMF L 500 ...	450	3	1	80 x 80 x 109	97 / 94	125	-	-	1	745,00
	IMF S 600 ...	600	4	2	104 x 78 x 101	81 / 78	125	1	1	-	810,00
	IMF S 750 ...	750	5	3	104 x 78 x 130	108 / 105	125	1	1	-	985,00
	IMF C 800 ...	840	6	3	130 x 130 x 97	78 / 76	125	1	1	-	855,00
	IMF C 1200 ...	1.180	8	4	130 x 130 x 128	108 / 106	125	1	1	-	1.090,00
	IMF C 1400 ...	1.500	10	5	130 x 130 x 150	131 / 129	125	1	1	-	1.265,00
	IMF C 1600 ...	1.680	12	6	130 x 130 x 172	153 / 151	125	1	1	-	1.470,00
	IMF C 2000 ...	1.920	13	7	130 x 130 x 194	175 / 173	125	1	1	-	1.645,00
	IMF CX 2100 ...	2.100	15	8	150 x 150 x 160	137 / 135	125	1	1	-	2.005,00
	IMF CX 2600 ...	2.600	18	10	150 x 150 x 182	159 / 157	125	1	1	-	2.300,00
	IMF CS 3000 ...	3.020	21	12	165 x 165 x 173	155 / 152	160	1	1	-	2.760,00
	IMF CS 3500 ...	3.500	25	14	165 x 165 x 196	175 / 172	160	1	1	-	2.920,00
	IMF CS 4000 ...	4.000	28	16	195 x 195 x 157	130 / 127	160	-	2	-	3.280,00
	IMF CS 4500 ...	4.500	32	18	195 x 195 x 178	153 / 150	160	-	2	-	3.765,00
	IMF CS 5100 ...	5.100	36	20	195 x 195 x 199	172 / 169	160	-	2	-	4.150,00
	IMF CR 5600 ...	5.600	40	22	230 x 230 x 188	155 / 153	160	-	2	-	5.125,00
	IMF MM 7500 ...	6.740	48	26	355 x 176 x 186	157 / 154	160	-	-	2	6.930,00
	IMF CR 7000 ...	7.000	50	28	230 x 230 x 218	181 / 179	160	-	2	-	5.670,00
	IMF N 9000 ...	7.520	53	30	285 x 210 x 234	195 / 192	160	1	-	1	7.170,00
	IMF MM 10000 ...	8.800	62	35	445 x 176 x 186	157 / 154	160	-	2	2	7.350,00
	IMF MM 11000 ...	10.450	74	41	535 x 176 x 186	157 / 154	160	-	2	2	9.960,00
	IMF M 12000 ...	11.880	84	47	440 x 210 x 234	206 / 201	160	-	-	2	11.655,00
	IMF MN 15000 ...	13.360	95	53	465 x 210 x 234	195 / 192	160	-	-	2	13.705,00
	IMF M 18000 ...	17.650	126	70	620 x 210 x 234	206 / 201	160	-	-	3	18.115,00
	IMF MN 21000 ...	19.130	136	76	645 x 210 x 234	195 / 192	160	-	-	3	20.475,00
	IMF M 24000 ...	23.420	167	93	800 x 210 x 234	206 / 201	160	-	-	4	23.310,00
	IMF MN 27000 ...	24.900	177	99	825 x 210 x 234	195 / 192	160	-	-	4	30.085,00
	IMF M 30000 ...	29.220	208	116	980 x 210 x 234	206 / 201	160	-	-	5	29.140,00
	IMF M 36000 ...	35.060	250	140	1.160 x 210 x 234	206 / 201	160	-	-	6	35.910,00
	IMF M 42000 ...	40.730	290	162	1.340 x 210 x 234	206 / 201	160	-	-	7	45.520,00

BIOLOGICAL | SECONDARY TREATMENT

ANAEROBIC TRICKLING FILTER FPN

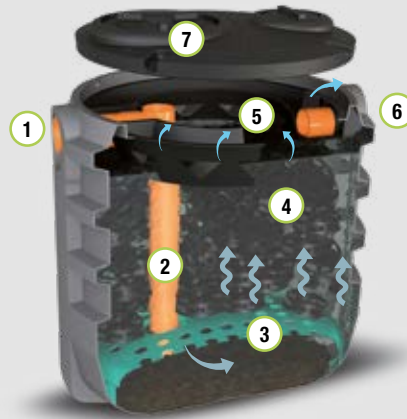

KEY

- ① Inlet pipe
- ② Bottom-up wastewater conveying pipe
- ③ Filling bodies supporting grid
- ④ Filtering mass (filling bodies)
- ⑤ Thomson Profile wastewater collection on the entire surface
- ⑥ Outlet pipe
- ⑦ Reinforced lid (with caps and vent)

WHERE TO USE IT



INSTALLATION SCHEME

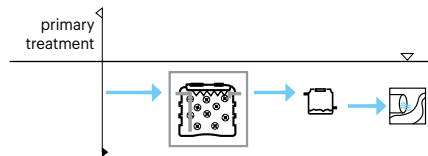



























FUNCTION AND USE

The anaerobic trickling filter is a tank in which the biodegradable substances dissolved in the wastewater are biologically treated. Inside the tank there are plastic elements with high specific surface, which have the function of favouring the engraftment of the adhered biomasses assigned to purification in absence of oxygen. It is used after adequate primary treatment.

STANDARDS AND CERTIFICATIONS

EN 12566-3

TECHNICAL TABLE - PRICE LIST

icon	model	volume liters	P.E. n.	Le x W x h cm	he / hu cm	Ø pipe in/out mm	caps Ø cm			€
							20	40	60	
	FPN L 500 T3	450	3	80 x 80 x 116	99 / 97	125	-	1	-	1.065,00
	FPN C 800 T3	840	5	130 x 130 x 97	78 / 76	125	1	1	-	1.420,00
	FPN C 1200 T3	1.180	7	130 x 130 x 128	108 / 106	125	1	1	-	1.735,00
	FPN C 1600 T3	1.680	11	130 x 130 x 172	153 / 151	125	1	1	-	2.365,00
	FPN C 2000 T3	1.920	12	130 x 130 x 194	175 / 173	125	1	1	-	3.120,00
	FPN CX 2100 T3	2.100	14	150 x 150 x 160	137 / 135	125	1	1	-	3.190,00
	FPN CX 2600 T3	2.600	17	150 x 150 x 182	159 / 157	125	1	1	-	3.795,00
	FPN CS 3000 T3	3.020	20	165 x 165 x 173	155 / 152	160	1	1	-	4.050,00
	FPN CS 3500 T3	3.500	23	165 x 165 x 196	175 / 172	160	1	1	-	4.495,00
	FPN CS 4000 T3	4.000	26	195 x 195 x 157	130 / 127	160	-	2	-	4.750,00
	FPN CS 4500 T3	4.500	30	195 x 195 x 178	153 / 150	160	-	2	-	5.440,00
	FPN CS 5100 T3	5.100	34	195 x 195 x 199	172 / 169	160	-	2	-	5.970,00
	FPN N 6000 T3	5.490	36	238 x 186 x 195	168 / 166	160	-	-	1	6.020,00
	FPN CR 5600 T3	5.600	38	230 x 230 x 188	155 / 153	160	-	2	-	6.145,00
	FPN CR 7000 T3	7.000	46	230 x 230 x 218	181 / 179	160	-	2	-	6.930,00
	FPN N 9000 T3	7.520	50	285 x 210 x 234	195 / 192	160	1	-	1	8.895,00
	FPN MM 8500 T3	7.990	55	415 x 176 x 186	157 / 154	160	-	-	2	10.005,00
	FPN MM 10000 T3	8.800	60	445 x 176 x 186	157 / 154	160	-	2	2	10.800,00
	FPN M 12000 T3	11.880	80	440 x 210 x 234	206 / 201	160	-	-	2	13.785,00
	FPN MN 15000 T3	13.360	90	465 x 210 x 234	195 / 192	160	-	-	2	15.270,00
	FPN M 18000 T3	17.650	120	620 x 210 x 234	206 / 201	160	-	-	3	20.790,00
	FPN MN 21000 T3	19.130	130	645 x 210 x 234	195 / 192	160	-	-	3	21.895,00
	FPN M 24000 T3	23.420	160	800 x 210 x 234	206 / 201	160	-	-	4	29.770,00
	FPN MN 27000 T3	24.900	170	825 x 210 x 234	195 / 192	160	-	-	4	30.600,00
	FPN M 30000 T3	29.220	200	980 x 210 x 234	206 / 201	160	-	-	5	31.345,00
	FPN M 36000 T3	35.060	240	1.160 x 210 x 234	206 / 201	160	-	-	6	36.000,00
	FPN M 42000 T3	40.730	270	1.340 x 210 x 234	206 / 201	160	-	-	7	51.030,00

BIOLOGICAL | SECONDARY TREATMENT

AEROBIC TRICKLING FILTER TOP OUTLET FPAH

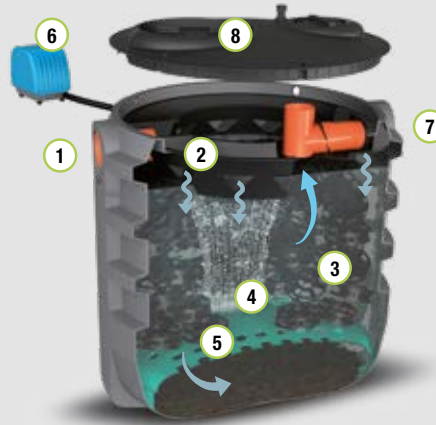

KEY

- ① Inlet pipe
- ② Thomson Profile wastewater distribution on the entire filtering mass
- ③ Filtering mass (filling bodies)
- ④ Air diffuser
- ⑤ Filling bodies supporting grid
- ⑥ Compressor / air blower
- ⑦ Outlet pipe
- ⑧ Reinforced lid (with caps and vent)

WHERE TO USE IT



INSTALLATION SCHEME

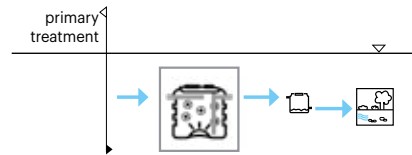

























FUNCTION AND USE

The aerobic trickling filter top outlet is a product which has the function of biologically treating the biodegradable organic substances dissolved in domestic or similar waste water. Aerobic digestion of the organic substances takes place in it through the bacterial flora adhering to filling bodies kept in suspension through the insufflation of air coming from microbubble diffusers powered by membrane compressor or channel blower. It is used after adequate primary treatment with the indication of installing, downstream of the system, a secondary sedimentation section using an Imhoff tank.

STANDARDS AND CERTIFICATIONS

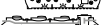
EN 12566-3

TECHNICAL TABLE - PRICE LIST

icon	model	volume liters	P.E. n.	Le x W x h cm	he / hu cm	Ø pipe in/out mm	caps Ø cm			€
							20	40	60	
							n.			
	FPAH C 800 T4	840	4	130 x 130 x 97	78 / 76	125	1	1	-	2.205,00 *
	FPAH C 1200 T4	1.180	7	130 x 130 x 128	108 / 106	125	1	1	-	3.075,00 *
	FPAH C 1600 T4	1.680	8	130 x 130 x 172	153 / 151	125	1	1	-	3.610,00 *
	FPAH C 2000 T4	1.920	10	130 x 130 x 194	175 / 173	125	1	1	-	4.140,00 *
	FPAH CX 2100 T4	2.100	12	150 x 150 x 160	137 / 135	125	1	1	-	4.410,00 *
	FPAH CX 2600 ...	2.600	14	150 x 150 x 182	159 / 157	125	1	1	-	4.635,00 *
	FPAH CS 3000 T4	3.020	16	165 x 165 x 173	155 / 152	160	1	1	-	5.475,00 *
	FPAH CS 3500 T4	3.500	18	165 x 165 x 196	175 / 172	160	1	1	-	5.985,00 *
	FPAH CS 4000 T4	4.000	22	195 x 195 x 157	130 / 127	160	-	2	-	6.435,00 *
	FPAH CS 4500 T4	4.500	24	195 x 195 x 178	153 / 150	160	-	2	-	7.125,00 *
	FPAH CS 5100 T4	5.100	28	195 x 195 x 199	172 / 169	160	-	2	-	7.980,00 *
	FPAH CR 5600 T4	5.490	32	230 x 230 x 188	155 / 153	160	-	2	-	8.535,00 *
	FPAH CR 7000 T4	5.600	36	230 x 230 x 218	181 / 179	160	-	2	-	10.815,00 *
	FPAH N 9000 T4	7.520	40	285 x 210 x 234	195 / 192	160	1	-	1	12.250,00
	FPAH MM 10000 T4	8.800	48	445 x 176 x 186	157 / 154	160	-	2	2	15.360,00
	FPAH MM 11000 T4	10.450	52	535 x 176 x 186	157 / 154	160	-	2	2	19.060,00
	FPAH M 12000 T4	11.880	60	440 x 210 x 234	206 / 201	160	-	-	2	18.890,00
	FPAH MN 15000 T4	13.360	70	465 x 210 x 234	195 / 192	160	-	-	2	24.850,00
	FPAH M 18000 T4	17.650	80	620 x 210 x 234	206 / 201	160	-	-	3	27.650,00
	FPAH MN 21000 T4	19.130	90	645 x 210 x 234	195 / 192	160	-	-	3	29.350,00
	FPAH M 24000 T4	23.420	100	800 x 210 x 234	206 / 201	160	-	-	4	32.890,00
	FPAH MN 27000 T4	24.900	112	825 x 210 x 234	195 / 192	160	-	-	4	35.450,00
	FPAH M 30000 T4	29.220	120	980 x 210 x 234	206 / 201	160	-	-	5	42.350,00
	FPAH M 36000 T4	35.060	140	1.160 x 210 x 234	206 / 201	160	-	-	6	48.555,00
	FPAH M 42000 T4	40.730	160	1.340 x 210 x 234	206 / 201	160	-	-	7	56.100,00

* command electric panel **excluded**

BIOLOGICAL | SECONDARY TREATMENT

ACTIVE SLUDGE WWTP DFA

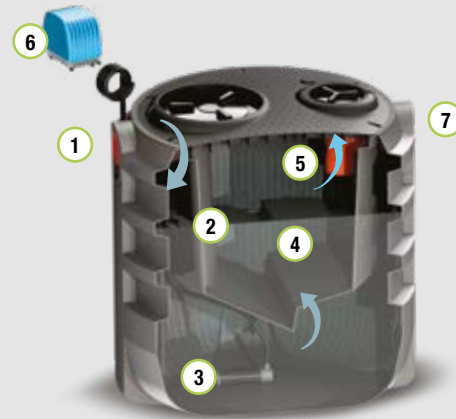

KEY

- ① Inlet pipe
- ② Active sludge oxidation chamber
- ③ Air diffuser
- ④ Secondary sedimentation
- ⑤ Clarified sewage upwelling
- ⑥ Compressor - air blower
- ⑦ Outlet pipe
- ⑧ Reinforced lid (with caps and vent)

WHERE TO USE IT



INSTALLATION SCHEME





























FUNCTION AND USE

The active sludge plant is a secondary treatment plant which has the function of biologically treating the organic substances present on a wastewater coming from domestic waste or similar, also guaranteeing a secondary sedimentation section inside. In it the aerobic digestion of organic substances takes place through the aerobic flora (active sludge), suspended due to the effect of insufflation of fine bubble air supplied by micro bubble diffusers fed by membrane compressor or channel blower. The clarification of the outgoing wastewater in the settling zone also takes place inside the tank. It is used after adequate primary treatment.

STANDARDS AND CERTIFICATIONS

EN 12566-3

TECHNICAL TABLE - PRICE LIST

icon	model	volume liters	P.E. n.	Le x W x h cm	he / hu cm	Ø pipe in/out mm	caps Ø cm			€
							20	40	60	
	DFA C 800 T4	840	3	130 x 130 x 97	78 / 76	125	1	1	-	2.145,00 *
	DFA C 1200 T4	1.180	5	130 x 130 x 128	108 / 106	125	1	1	-	2.605,00 *
	DFA C 1600 T4	1.680	6	130 x 130 x 172	153 / 151	125	1	1	-	2.760,00 *
	DFA C 2000 T4	1.920	8	130 x 130 x 194	175 / 173	125	1	1	-	3.465,00 *
	DFA CX 2100 T4	2.100	9	150 x 150 x 160	137 / 135	125	1	1	-	3.795,00 *
	DFA CX 2600 T4	2.600	10	150 x 150 x 182	159 / 157	125	1	1	-	4.255,00 *
	DFA CS 3000 T4	3.020	12	165 x 165 x 173	155 / 152	160	1	1	-	4.710,00 *
	DFA CS 3500 T4	3.500	13	165 x 165 x 196	175 / 172	160	1	1	-	5.200,00 *
	DFA CS 4000 T4	4.000	16	195 x 195 x 157	130 / 127	160	-	2	-	5.515,00 *
	DFA CS 4500 T4	4.500	18	195 x 195 x 178	153 / 150	160	-	2	-	6.225,00 *
	DFA CS 5100 T4	5.100	21	195 x 195 x 199	172 / 169	160	-	2	-	7.170,00 *
	DFA CR 5600 T4	5.600	24	230 x 230 x 188	155 / 153	160	-	2	-	8.665,00 *
	DFA CR 7000 T4	7.000	28	230 x 230 x 218	181 / 179	160	-	2	-	10.395,00 *
	DFA N 9000 T4	7.520	29	285 x 210 x 234	195 / 192	160	1	-	1	11.815,00
	DFA MM 8500 T4	7.990	30	415 x 176 x 186	157 / 154	160	-	-	2	13.230,00
	DFA MM 10000 T4	8.800	36	445 x 176 x 186	157 / 154	160	-	2	2	14.335,00
	DFA MM 11000 T4	10.450	41	535 x 176 x 186	157 / 154	160	-	3	2	15.595,00
	DFA M 12000 T4	11.880	49	440 x 210 x 234	206 / 201	160	-	-	2	16.380,00
	DFA MN 15000 T4	13.360	54	465 x 210 x 234	195 / 192	160	-	-	2	19.060,00
	DFA M 18000 T4	17.650	73	620 x 210 x 234	206 / 201	160	-	-	3	24.730,00
	DFA MN 21000 T4	19.130	77	645 x 210 x 234	195 / 192	160	-	-	3	27.565,00
	DFA M 24000 T4	23.420	93	800 x 210 x 234	206 / 201	160	-	-	4	31.345,00
	DFA MN 27000 T4	24.900	100	825 x 210 x 234	195 / 192	160	-	-	4	35.995,00
	DFA M 30000 T4	29.220	106	980 x 210 x 234	206 / 201	160	-	-	5	39.060,00
	DFA M 36000 T4	35.060	126	1.160 x 210 x 234	206 / 201	160	-	-	6	47.095,00
	DFA M 42000 T4	40.730	160	1.340 x 210 x 234	206 / 201	160	-	-	7	62.685,00

* command electric panel **excluded**

BIOLOGICAL | SECONDARY TREATMENT

ACTIVE SLUDGE WWTP TYPE: "LAGOON" DFA LA



KEY

- ① Inlet pipe
- ② Aerobic oxidation chamber
- ③ Filling bodies
- ④ Air diffuser
- ⑤ Secondary sedimentation
- ⑥ Clarified sewage upwelling
- ⑦ Compressor - air blower
- ⑧ Outlet pipe
- ⑨ Reinforced lid (with caps and vent)

WHERE TO USE IT



INSTALLATION SCHEME

















FUNCTION AND USE

The active sludge plant type "Lagoon" is a secondary treatment plant which has the function of biologically treating the organic substances present on a wastewater coming from domestic or similar wastewater, also guaranteeing a secondary sedimentation section inside. In it the aerobic digestion of the organic substances takes place through the bacterial flora adhered to plastic filling bodies kept in suspension by insufflation of fine-bubbled air supplied by micro-bubble diffusers fed by membrane compressor or channel blower. The clarification of the outgoing wastewater in the settling zone also takes place inside the tank. It is used after adequate primary treatment for discharges falling within the area of Venice Lagoon.

STANDARDS AND CERTIFICATIONS

EN 12566-3

TECHNICAL TABLE - PRICE LIST

icon	model	volume liters	P.E. n.	Le x W x h cm	he / hu cm	Ø pipe in/out mm	caps Ø cm			€
							20	40	60	
							n.			
	DFA C 800 LA	840	5	130 x 130 x 97	78 / 76	125	1	1	-	2.145,00 *
	DFA C 1200 LA	1180	8	130 x 130 x 128	108 / 106	125	1	1	-	2.605,00 *
	DFA C 1600 LA	1680	10	130 x 130 x 172	153 / 151	125	1	1	-	2.760,00 *
	DFA C 2000 LA	1920	12	130 x 130 x 194	175 / 173	125	1	1	-	3.465,00 *
	DFA CX 2100 LA	2100	14	150 x 150 x 160	137 / 135	125	1	1	-	3.795,00 *
	DFA CX 2600 LA	2600	16	150 x 150 x 182	159 / 157	125	1	1	-	4.255,00 *
	DFA CS 3000 LA	3020	18	165 x 165 x 173	155 / 152	160	1	1	-	4.710,00 *
	DFA CS 3500 LA	3500	20	165 x 165 x 196	175 / 172	160	1	1	-	5.200,00 *
	DFA CS 4000 LA	4000	24	195 x 195 x 157	130 / 127	160	-	2	-	5.515,00 *
	DFA CS 4500 LA	4500	28	195 x 195 x 178	153 / 150	160	-	2	-	6.225,00 *
	DFA CS 5100 LA	5100	32	195 x 195 x 199	172 / 169	160	-	2	-	7.170,00 *
	DFA CR 5600 LA	5600	36	230 x 230 x 188	155 / 153	160	-	2	-	8.665,00 *
	DFA CR 7000 LA	7000	42	230 x 230 x 218	181 / 179	160	-	2	-	10.395,00 *
	DFA N 9000 LA	7520	44	285 x 210 x 234	195 / 192	160	1	-	1	11.815,00
	DFA MM 10000 LA	8800	54	445 x 176 x 186	157 / 154	160	-	2	2	14.335,00

* command electric panel **excluded**

BIOLOGICAL | SECONDARY TREATMENT

SUPER SECONDARY WWTP TYPE: ISS

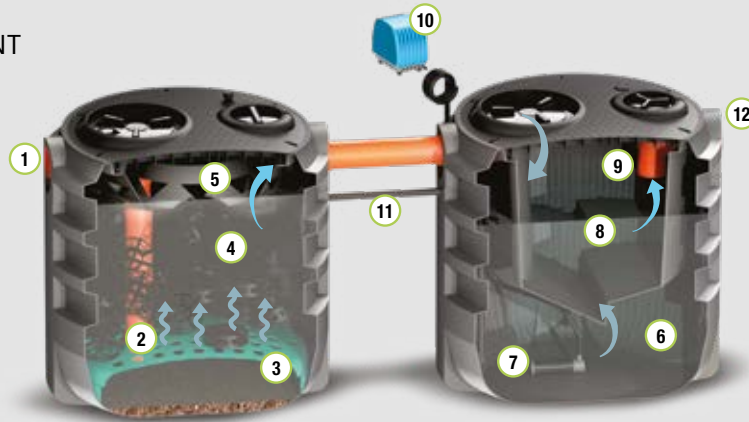

KEY

- | | |
|---|---------------------------------------|
| ① Inlet pipe | ⑦ Air diffuser |
| ② Bottom-up wastewater conveying pipe | ⑧ Secondary sedimentation |
| ③ Filling bodies supporting grid | ⑨ Clarified sewage upwelling |
| ④ Filtering mass (filling bodies) | ⑩ Compressor - blower |
| ⑤ Thomson Profile wastewater collection on the entire surface | ⑪ Recirculation air-lift |
| ⑥ Active sludge oxidation chamber | ⑫ Outlet pipe |
| | ⑬ Reinforced lid (with caps and vent) |

WHERE TO USE IT



INSTALLATION SCHEME



FUNCTION AND USE

The super secondary plant is made up of two products which provide for treatments using an anaerobic trickling filter and an active sludge plant. The double secondary treatment which compose the plant allows the water to be discharged onto the ground or, in the event that sludge recirculation is added using the special AIR - LIFT, to be reused for irrigation purposes. The waters, adequately pretreated, are introduced into the first tank in which the anaerobic purification of the wastewater takes place thanks to the biomass adhering to the filling bodies. In the second section, the aerobic digestion of the organic substances takes place through the suspended bacterial flora as a result of the insufflation of air supplied by powered micro-bubble diffusers fed by membrane compressor. The latter tank is equipped with a final clarification area in which the suspended sludge is separated before leaving the plant.

STANDARDS AND CERTIFICATIONS

EN 12566-3

TECHNICAL TABLE - PRICE LIST

icon	model	volume liters	P.E. n.	Le x W x h cm	he / hu cm	Ø pipe in/out mm	caps Ø cm		plant composition				T4	RI
							20	40	artifact	volume	artifact	volume	€	
							n.	n.	mod.	liters	mod.	liters		
	ISS C 1680 T4/RI	1.680	6	310 x 130 x 97	78 / 76	125	2	2	FPN C 800	840	DFA C 800	840	3.270,00 *	3.870,00 *
	ISS C 2020 T4/RI	2.020	8	310 x 130 x 128	108 / 106	125	2	2	FPN C 800	840	DFA C 1200	1.180	3.600,00 *	4.200,00 *
	ISS C 2360 T4/RI	2.360	9	310 x 130 x 128	108 / 106	125	2	2	FPN C 1200	1180	DFA C 1200	1.180	3.885,00 *	4.485,00 *
	ISS C 2860 T4/RI	2.860	11	310 x 130 x 172	153 / 151	125	2	2	FPN C 1200	1180	DFA C 1600	1.680	4.110,00 *	4.710,00 *
	ISS C 3360 T4/RI	3.360	13	310 x 130 x 172	153 / 151	125	2	2	FPN C 1600	1680	DFA C 1600	1.680	4.980,00 *	5.730,00 *
	ISS C 3600 T4/RI	3.600	14	310 x 130 x 194	175 / 173	125	2	2	FPN C 1600	1680	DFA C 2000	1.920	5.550,00 *	6.300,00 *
	ISS C 3840 T4/RI	3.840	15	310 x 130 x 194	175 / 173	125	2	2	FPN C 2000	1920	DFA C 2000	1.920	6.585,00 *	7.335,00 *
	ISS CX 4020 T4/RI	4.020	16	330 x 150 x 194	175 / 173	125	2	2	FPN C 2000	1920	DFA CX 2100	2.100	6.765,00 *	7.515,00 *
	ISS CX 4700 T4/RI	4.700	18	350 x 150 x 182	159 / 157	125	2	2	FPN CX 2100	2100	DFA CX 2600	2.600	7.140,00 *	7.890,00 *
	ISS CX 5200 T4/RI	5.200	20	350 x 150 x 182	159 / 157	125	2	2	FPN CX 2600	2600	DFA CX 2600	2.600	7.485,00 *	8.235,00 *
	ISS CS 5620 T4/RI	5.620	22	355 x 165 x 182	159 / 157	160	2	2	FPN CX 2600	2600	DFA CS 3000	3.020	8.325,00 *	9.075,00 *
	ISS CS 6040 T4/RI	6.040	24	380 x 165 x 173	155 / 152	160	2	2	FPN CS 3000	3020	DFA CS 3000	3.020	8.625,00 *	9.390,00 *
	ISS CS 6520 T4/RI	6.520	26	380 x 165 x 198	175 / 172	160	2	2	FPN CS 3000	3020	DFA CS 3500	3.500	8.865,00 *	9.615,00 *
	ISS CS 7000 T4/RI	7.000	28	380 x 165 x 198	175 / 172	160	2	2	FPN CS 3500	3500	DFA CS 3500	3.500	9.180,00 *	10.080,00 *
	ISS CS 7500 T4/RI	7.500	30	410 x 195 x 196	175 / 172	160	1	3	FPN CS 3500	3500	DFA CS 4000	4.000	9.450,00 *	10.350,00 *
	ISS CS 8000 T4/RI	8.000	32	440 x 195 x 157	130 / 127	160	-	4	FPN CS 4000	4000	DFA CS 4000	4.000	9.765,00 *	10.665,00 *
	ISS CS 8500 T4/RI	8.500	34	440 x 195 x 178	153 / 150	160	-	4	FPN CS 4000	4000	DFA CS 4500	4.500	10.875,00 *	11.775,00 *
	ISS CS 9000 T4/RI	9.000	36	440 x 195 x 178	153 / 150	160	-	4	FPN CS 4500	4500	DFA CS 4500	4.500	11.700,00 *	12.600,00 *
	ISS CS 9600 T4/RI	9.600	38	440 x 195 x 199	172 / 169	160	-	4	FPN CS 4500	4500	DFA CS 5100	5.100	12.840,00 *	13.740,00 *
	ISS CS 10200 T4/RI	10.200	40	440 x 195 x 199	172 / 169	160	-	4	FPN CS 5100	5100	DFA CS 5100	5.100	13.485,00 *	14.985,00 *
	ISS CR 10700 T4/RI	10.700	42	475 x 230 x 199	172 / 169	160	-	4	FPN CS 5100	5100	DFA CR 5600	5.600	14.640,00 *	16.140,00 *
	ISS CR 11200 T4/RI	11.200	44	510 x 230 x 188	157 / 154	160	-	4	FPN CR 5600	5600	DFA CR 5600	5.600	15.315,00 *	16.815,00 *
	ISS CR 12600 T4/RI	12.600	50	510 x 230 x 218	181 / 179	160	-	4	FPN CR 5600	5600	DFA CR 7000	7.000	16.410,00 *	17.910,00 *
	ISS CR 14000 T4/RI	14.000	56	510 x 230 x 218	181 / 179	160	-	4	FPN CR 7000	7000	DFA CR 7000	7.000	18.150,00 *	19.650,00 *

T4: SOIL
RI: REUSE

* command electric panel **excluded**

BIOLOGICAL | COMPLETE TREATMENT

SEPTIC TANK WITH FILTER SET



KEY

- ① Inlet pipe
- ② Settling chamber
- ③ Sedimented sludge digestion
- ④ Outlet pipe
- ⑤ Reinforced lid (with caps and vent)
- ⑥ Tank with filters

WHERE TO USE IT



INSTALLATION SCHEME

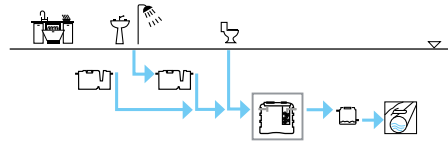



FUNCTION AND USE

The single-chamber septic tank with filter is generally used as a primary and secondary treatment of black wastewater from residential buildings or similar discharges. It is equipped with a filtration section installed on the outlet pipe, inside which filling bodies in plastic material with a high specific surface area of $120\text{m}^2/\text{m}^3$ are positioned. Upstream of it, it is advisable to position a grease separator with the aim of eliminating the oils and greases present in the sewage arriving at the tank. The outgoing wastewater can be discharged in Public Sewer or in surface waters.

STANDARDS AND CERTIFICATIONS

EN 12566-1

TECHNICAL TABLE - PRICE LIST

icon	model	volume liters	P.E. n.	Le x W x h cm	he / hu cm	Ø pipe in/out mm	caps Ø cm			price list €
							20	40	60	
	SET C 800 SM F	840	6	130 x 130 x 97	78 / 76	125	1	1	-	920,00
	SET C 1200 SM F	1.180	8	130 x 130 x 128	108 / 106	125	1	1	-	1.120,00
	SET C 1400 SM F	1.500	10	130 x 130 x 150	131 / 129	125	1	1	-	1.285,00
	SET C 1600 SM F	1.680	12	130 x 130 x 172	153 / 151	125	1	1	-	1.360,00
	SET C 2000 SM F	1.920	14	130 x 130 x 194	175 / 173	125	1	1	-	1.600,00
	SET CX 2100 SM F	2.100	15	150 x 150 x 160	137 / 135	125	1	1	-	1.705,00
	SET CX 2600 SM F	2.600	18	150 x 150 x 182	159 / 157	125	1	1	-	2.065,00
	SET CS 3000 SM F	3.020	21	165 x 165 x 173	155 / 152	160	1	1	-	2.500,00
	SET CS 3500 SM F	3.500	25	165 x 165 x 196	175 / 172	160	1	1	-	2.840,00
	SET CS 4000 SM F	4.000	28	195 x 195 x 157	130 / 127	160	-	2	-	3.385,00
	SET CS 4500 SM F	4.500	32	195 x 195 x 178	153 / 150	160	-	2	-	3.520,00
	SET CS 5100 SM F	5.100	36	195 x 195 x 199	172 / 169	160	-	2	-	4.015,00
	SET CR 5600 SM F	5.600	40	230 x 230 x 188	155 / 153	160	-	2	-	4.150,00
	SET CR 7000 SM F	7.000	50	230 x 230 x 218	181 / 179	160	-	2	-	5.125,00

BIOLOGICAL | COMPLETE PLANTS

AEROBIC TRICKLING FILTER TOP OUTLET WITH SEDIMENTATION FSAH

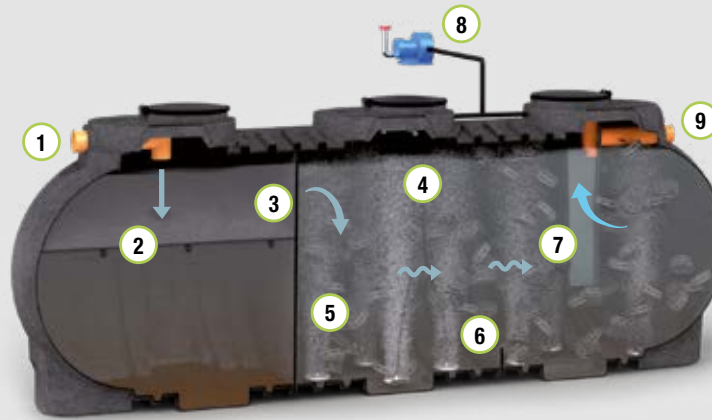

KEY

- ① Inlet pipe
- ② Primary sedimentation
- ③ Trickling filter power supply
- ④ Sewage distribution
- ⑤ Filtering mass (filling bodies)
- ⑥ Air diffuser
- ⑦ Settling perforated cone
- ⑧ Air blower
- ⑨ Outlet pipe

WHERE TO USE IT



INSTALLATION SCHEME

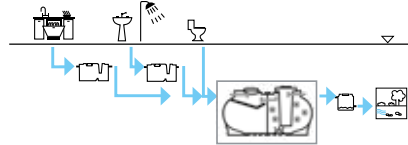













FUNCTION AND USE

The aerobic trickling filter top outlet with sedimentation is a tank that has the function of treating the wastewater in a complete way; the product is made up of two compartments: the first for primary sedimentation, the second for biological treatment through aerobic digestion of organic substances through biomass adhered to elements in polypropylene with high specific surface and moved by air blowing. It is installed downstream of blonde and gray water pre-treatment plants (grease separators).

STANDARDS AND CERTIFICATIONS

EN 12566-1/3

TECHNICAL TABLE - PRICE LIST

icon	model	volume liters	P.E. n.	Le x W x h cm	he / hu cm	Ø pipe in/out mm	caps Ø cm		€
							40	60	
							n.		
	FSAH MM 7500 T4	6.740	18	355 x 176 x 186	157 / 154	160	-	2	13.500,00
	FSAH MM 8500 T4	7.990	21	415 x 176 x 186	157 / 154	160	-	2	14.900,00
	FSAH MM 10000 T4	8.800	23	445 x 176 x 186	157 / 154	160	2	2	16.400,00
	FSAH MM 11000 T4	10.450	28	535 x 176 x 186	157 / 154	160	3	2	17.995,00
	FSAH M 12000 T4	11.880	32	440 x 210 x 234	206 / 201	160	-	2	18.575,00
	FSAH MN 15000 T4	13.360	36	465 x 210 x 234	195 / 192	160	-	2	20.440,00
	FSAH M 18000 T4	17.650	47	620 x 210 x 234	206 / 201	160	-	3	28.440,00
	FSAH MN 21000 T4	19.130	51	645 x 210 x 234	195 / 192	160	-	3	30.190,00
	FSAH M 24000 T4	23.420	63	800 x 210 x 234	206 / 201	160	-	4	34.550,00
	FSAH MN 27000 T4	24.900	67	825 x 210 x 234	195 / 192	160	-	4	38.600,00
	FSAH M 30000 T4	29.220	78	980 x 210 x 234	206 / 201	160	-	5	41.720,00
	FSAH M 36000 T4	35.060	94	1.160 x 210 x 234	206 / 201	160	-	6	49.890,00
	FSAH M 42000 T4	40.730	110	1.340 x 210 x 234	206 / 201	160	-	7	56.460,00

BIOLOGICAL | COMPLETE PLANTS

TOTAL OXIDATION WWTP DIRECT INLET IOT

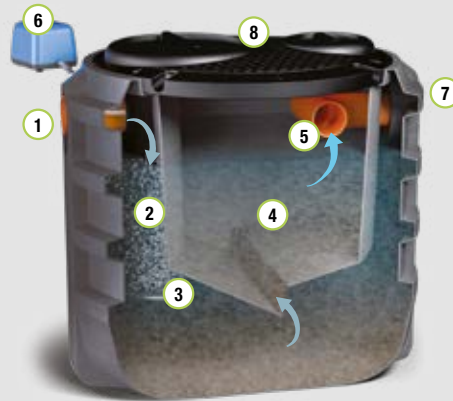

KEY

- ① Inlet pipe
- ② Active sludge oxidation chamber
- ③ Air diffuser
- ④ Secondary sedimentation
- ⑤ Clarified sludge upwelling
- ⑥ Compressor - air blower
- ⑦ Outlet pipe
- ⑧ Reinforced lid (with caps and vent)

WHERE TO USE IT



INSTALLATION SCHEME

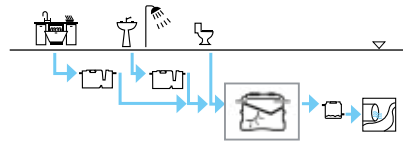















FUNCTION AND USE

The total oxidation plant is a product that has the function of treating in a complete way the wastewater through the biological removal of organic substances and ensuring a secondary sedimentation. Aerobic digestion of organic substances takes place in it thanks to aerobic flora suspended through air insufflation and subsequent clarification in the settling area. The total oxidation plant is used for the direct treatment (with a high inflow charge) of wastewater from residential buildings or similar wastewater.

STANDARDS AND CERTIFICATIONS

EN 12566-3

TECHNICAL TABLE - PRICE LIST

icon	model	volume liters	P.E. n.	Le x W x h cm	he / hu cm	Ø pipe in/out mm	caps Ø cm			€
							20	40	60	
							n.			
	IOT C 800 T3	840	2	130 x 130 x 97	78 / 76	125	1	1	-	2.145,00 *
	IOT C 1200 T3	1.180	3	130 x 130 x 128	108 / 106	125	1	1	-	2.605,00 *
	IOT C 1600 T3	1.680	4	130 x 130 x 172	153 / 151	125	1	1	-	2.760,00 *
	IOT C 2000 T3	1.920	5	130 x 130 x 194	175 / 173	125	1	1	-	3.465,00 *
	IOT CX 2100 T3	2.100	6	150 x 150 x 160	137 / 135	125	1	1	-	3.795,00 *
	IOT CX 2600 T3	2.600	7	150 x 150 x 182	159 / 157	125	1	1	-	4.255,00 *
	IOT CS 3000 T3	3.020	8	165 x 165 x 173	155 / 152	160	1	1	-	4.710,00 *
	IOT CS 3500 T3	3.500	9	165 x 165 x 196	175 / 172	160	1	1	-	5.250,00 *
	IOT CS 4000 T3	4.000	10	195 x 195 x 157	130 / 127	160	-	2	-	5.515,00 *
	IOT CS 4500 T3	4.500	12	195 x 195 x 178	153 / 150	160	-	2	-	6.225,00 *
	IOT CS 5100 T3	5.100	13	195 x 195 x 199	172 / 169	160	-	2	-	7.170,00 *
	IOT CR 5600 T3	5.600	14	230 x 230 x 188	155 / 153	160	-	2	-	8.665,00 *
	IOT CR 7000 T3	7.000	18	230 x 230 x 218	181 / 179	160	-	2	-	10.395,00 *
	IOT MM 8500 T3	7.990	22	415 x 176 x 186	157 / 154	160	-	-	2	13.390,00 *
	IOT MM 10000 T3	8.800	25	445 x 176 x 186	157 / 154	160	-	2	2	14.335,00 *

* command electric panel **excluded**

BIOLOGICAL | COMPLETE PLANTS

BIOLOGICAL OXIDATION WWTP IOB

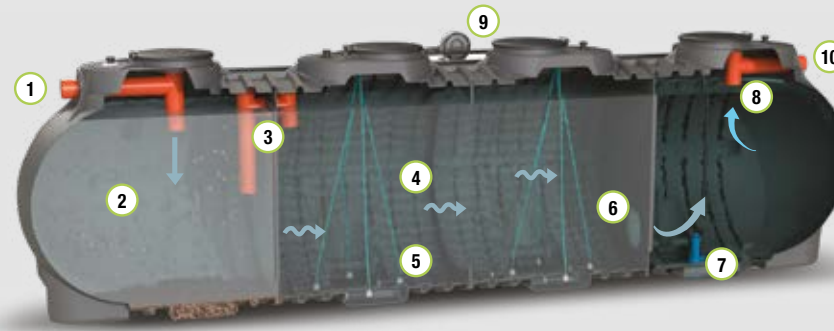

KEY

- ① Inlet pipe
- ② Primary sedimentation
- ③ Active sludge section supply
- ④ Active sludge oxidation chamber
- ⑤ Air diffusers
- ⑥ Secondary sedimentation supply
- ⑦ Sludge recirculation with pump
- ⑧ Clarified sewage upwelling
- ⑨ Compressor - air blower
- ⑩ Outlet pipe

WHERE TO USE IT



INSTALLATION SCHEME

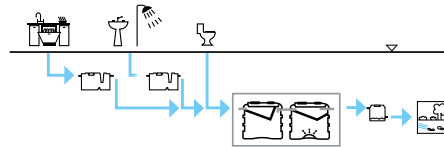



















FUNCTION AND USE

The biological oxidation plant has the function of treating the wastewater in a complete way. It is made up of three compartments: the first has the function of primary sedimentation, the second of biological treatment of organic substances through active sludge suspended by air insufflation, while the third has the function of secondary sedimentation and clarification of the wastewater. In the third compartment there is generally a system for the recirculation of sludge at the top of the plant. The blonde and gray waters, before being introduced into the plant, must be pre-treated in adequate grease separator.

STANDARDS AND CERTIFICATIONS

EN 12566-1/3

TECHNICAL TABLE - PRICE LIST

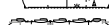
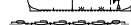
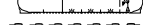
icon	model	volume liters	P.E. n.	Le x W x h cm	he / hu cm	Ø pipe in/out mm	caps Ø cm			€
							20	40	60	
composed artifacts										
	IOB C 800 T4	1.680	3	310 x 130 x 97	78 / 76	125	2	2	-	3.555,00 *
	IOB C 1200 T4	2.360	5	310 x 130 x 97	78 / 106	125	2	2	-	4.010,00 *
	IOB C 1600 T4	3.360	6	310 x 130 x 172	153 / 151	125	2	2	-	4.785,00 *
	IOB C 2000 T4	3.840	8	310 x 130 x 194	175 / 173	125	2	2	-	5.665,00 *
	IOB CX 2100 T4	4.200	9	350 x 150 x 160	137 / 135	125	2	2	-	6.625,00 *
	IOB CX 2600 T4	5.200	10	350 x 150 x 182	159 / 157	125	2	2	-	7.015,00 *
	IOB CS 3000 T4	6.040	12	380 x 165 x 175	158 / 155	160	2	2	-	8.025,00 *
	IOB CS 3500 T4	7.000	13	380 x 165 x 197	180 / 177	160	2	2	-	8.670,00 *
	IOB CS 4000 T4	8.000	16	440 x 195 x 160	134 / 131	160	1	3	-	9.345,00 *
	IOB CS 4500 T4	9.000	18	440 x 195 x 182	156 / 153	160	1	3	-	10.545,00 *
	IOB CS 5100 T4	10.200	21	440 x 195 x 204	178 / 175	160	1	3	-	11.875,00 *
	IOB CR 5600 T4	11.200	24	510 x 230 x 188	157 / 154	160	1	3	-	14.340,00 *
	IOB CR 7000 T4	14.000	30	510 x 230 x 218	190 / 188	160	-	4	-	16.620,00 *
	IOB MM 10000 T4	15.800	40	725 x 230 x 218	190 / 188	160	-	2	2	20.475,00
modular artifacts										
	IOB M 12000 T4	11.880	34	440 x 210 x 234	206 / 201	160	-	-	2	17.550,00
	IOB M 18000 T4	17.650	48	620 x 210 x 234	206 / 201	160	-	-	3	27.750,00
	IOB M 24000 T4	23.420	64	800 x 210 x 234	206 / 201	160	-	-	4	33.750,00
	IOB MN 27000 T4	24.900	70	825 x 210 x 234	195 / 192	160	-	-	4	37.200,00
	IOB M 30000 T4	29.220	80	980 x 210 x 234	206 / 201	160	-	-	5	41.250,00
	IOB M 36000 T4	35.060	95	1.160 x 210 x 234	206 / 201	160	-	-	6	45.750,00
	IOB M 42000 T4	40.730	110	1.340 x 210 x 234	206 / 201	160	-	-	7	63.000,00

* command electric panel **excluded**

ACTIVE SLUDGE WWTP WITH CONSTANT FLOW RATE IFA PC

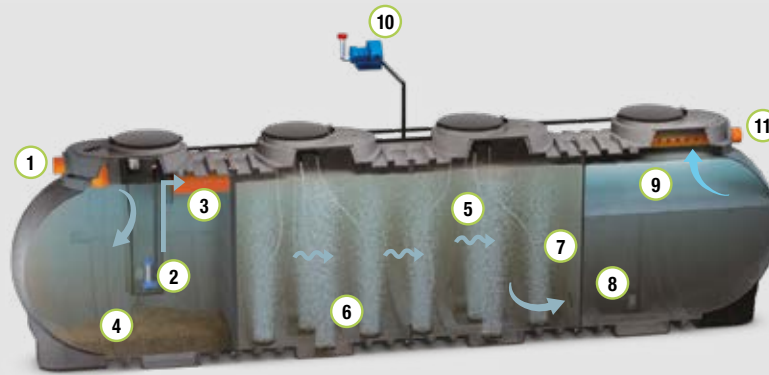

KEY

- 1 Inlet pipe
- 2 Equalization tank with pump and manual regulation of the flow rate
- 3 Active sludge section supply emergency overflow
- 4 Equalization section
- 5 Aerobic oxidation chamber
- 6 Air diffusers
- 7 Secondary sedimentation supply
- 8 Sludge recirculation with pump
- 9 Clarified sewage upwelling
- 10 Air blower
- 11 Outlet pipe

WHERE TO USE IT



INSTALLATION SCHEME

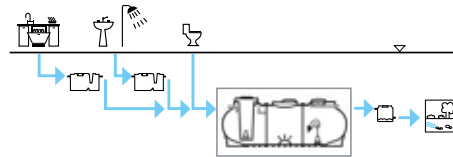

FUNCTION AND USE





The active sludge plant with constant flow rate has the function of treating in a complete way the wastewater and is generally used on users that have punctual discharges during the day. It is made up of three compartments: the first has the function of primary sedimentation and flow equalization which allows to feed the secondary section with constant flow rate avoiding the hydraulic charge peaks, the second of biological treatment of the organic substances through suspended activated sludge by air insufflation, while the third has the function of secondary settler and wastewater clarification.

In the third compartment there is generally a system for the recirculation of sludge at the top of the plant. Prior to being introduced into the system, the blonde and gray waters must be pre-treated in adequate grease separator.

STANDARDS AND CERTIFICATIONS

EN 12566-1/3

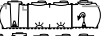
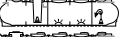
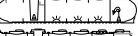
TECHNICAL TABLE - PRICE LIST

icon	model	volume liters	P.E. n.	Le x W x h cm	he / hu cm	Ø pipe in/out mm	caps Ø cm		€
							60	n.	
	IFA PC M 18000 T4	17.650	40	620 x 210 x 234	206 / 201	160	3		24.570,00
	IFA PC MN 21000 T4	19.130	50	645 x 210 x 234	195 / 192	160	3		28.350,00
	IFA PC M 24000 T4	23.420	60	800 x 210 x 234	206 / 201	160	4		32.130,00
	IFA PC MN 27000 T4	24.900	70	825 x 210 x 234	195 / 192	160	4		35.595,00
	IFA PC M 30000 T4	29.220	85	980 x 210 x 234	206 / 201	160	5		38.115,00
	IFA PC M 36000 T4	35.060	105	1.160 x 210 x 234	206 / 201	160	6		46.935,00
	IFA PC M 42000 T4	40.730	120	1.340 x 210 x 234	206 / 201	160	7		57.015,00

BIOLOGICAL | COMPLETE PLANTS

AERATED BIOFILTRATION MBBR

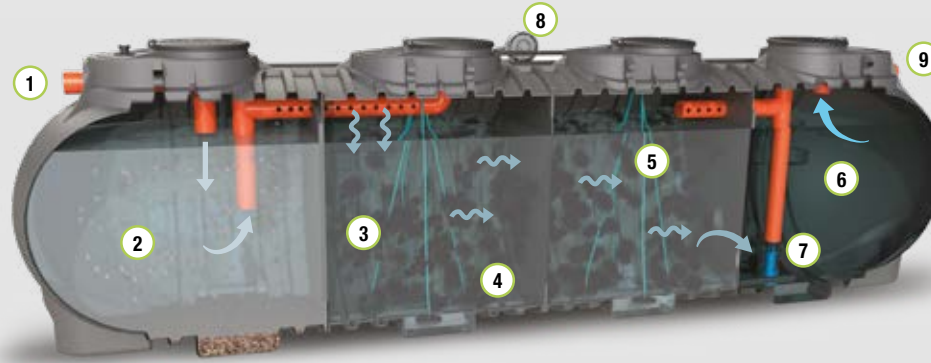

KEY

- ① Inlet pipe
- ② Primary sedimentation
- ③ Fluid bed aerobic digestion chamber
- ④ Micro-bubble diffuser
- ⑤ Fluid bed (Carrier)
- ⑥ Secondary sedimentation
- ⑦ Sludge recirculation pump
- ⑧ Blower-compressor
- ⑨ Outlet pipe

WHERE TO USE IT



INSTALLATION SCHEME

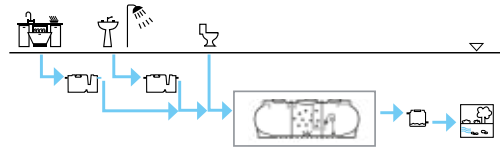

FUNCTION AND USE

The MBBR plant is a tank that has the function of treating the wastewater in a complete way. The tank has three compartments: the first has the function of primary sedimentation, the second of biological treatment of organic substances through aerated floating bed biofiltration with bacterial flora adhered to filling bodies with a high specific surface area (carrier), while the third has the function of secondary settler. In the secondary sedimentation there is a single-phase pump for the recirculation of the sludge at the top of the plant. The blonde and gray waters must be pre-treated.

STANDARDS AND CERTIFICATIONS

EN 12566-1/3

TECHNICAL TABLE - PRICE LIST

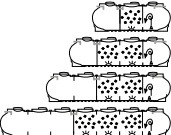
icon	model	volume liters	P.E. n.	Le x W x h cm	he / hu cm	Ø pipe in/out mm	caps Ø cm		€
							40	60	
							n.		
	MBBR MM 7500 T4	11.840	25	600 x 195 x 199	172 / 154	160	2	2	29.925,00
	MBBR MM 10000 T4	14.400	35	725 x 230 x 188	155 / 154	160	4	2	33.865,00
	MBBR M 18000 T4	17.650	40	620 x 210 x 234	206 / 201	160	-	3	38.205,00
	MBBR M 24000 T4	23.420	55	800 x 210 x 234	206 / 201	160	-	4	52.605,00
	MBBR M 30000 T4	29.220	70	980 x 210 x 234	206 / 201	160	-	5	61.770,00
	MBBR M 42000 T4	40.730	100	1.340 x 210 x 234	206 / 201	160	-	7	83.160,00

BIOLOGICAL | COMPLETE PLANTS

SEQUENCING BATCH REACTOR SBR

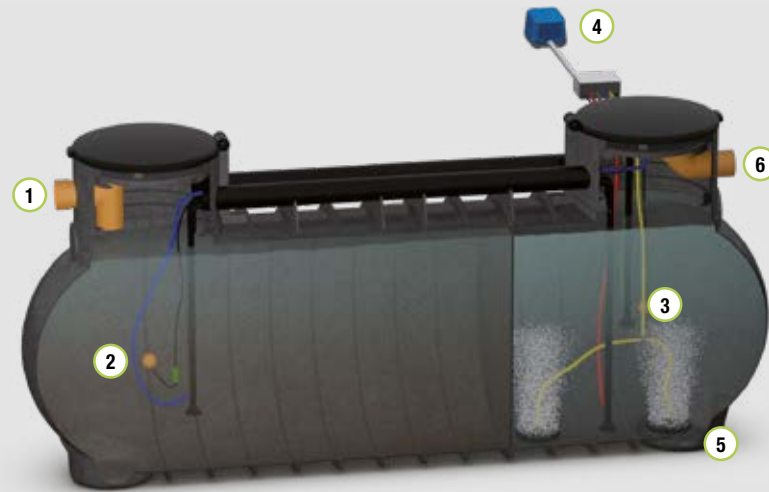

KEY

- ① Inlet pipe
- ② Equalization / primary sedimentation chamber
- ③ Oxidation / secondary sedimentation chamber
- ④ Blower
- ⑤ Diffusers
- ⑥ Outlet pipe

WHERE TO USE IT



INSTALLATION SCHEME

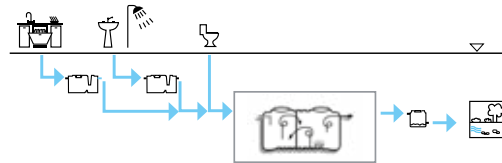

FUNCTION AND USE

The SBR plant is a tank that has the function of completely treating the wastewater. The wastewater treatment plant must be used for incoming wastewater consisting only of domestic waste: these must be no rainwater or other types of liquid inputs. There are two compartments in the tank: the first has the function of sedimentation/equalization of the incoming wastewater, the second of biological treatment of organic substances through activated sludge and secondary sedimentation with sludge recirculation to the first compartment.





A series of air-lifts controlled in sequence by a PLC panel govern the alternating purification cycles.

Pre-treatment of blonde and gray waters is recommended.

STANDARDS AND CERTIFICATIONS

EN 12566-3

TECHNICAL TABLE - PRICE LIST

icon	model	volume liters	P.E. n.	Le x W x h cm	he / hu cm	Ø pipe in/out mm	equalization primary sediment. lt	oxidation secondary sediment. lt	blower kW	diffusers n.	€
	SBR MM 7500 T4	6.740	12	355 x 176 x 186	157 / 154	160	2500	4240	0,08	2	14.600,00
	SBR MM 8500 T4	7.990	15	415 x 176 x 186	157 / 154	160	3000	4990	0,08	2	16.400,00
	SBR MM 10000 T4	8.800	18	445 x 176 x 186	157 / 154	160	3500	5300	0,12	3	18.400,00
	SBR MM 11000 T4	10.450	20	535 x 176 x 186	157 / 154	160	4200	6250	0,15	3	21.200,00

BIOLOGICAL

AURORA

WHERE TO USE IT



injection covers



rings without sedimentation

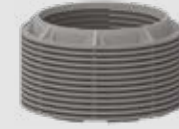

rings with sedimentation



moulded covers



SOLUTIONS

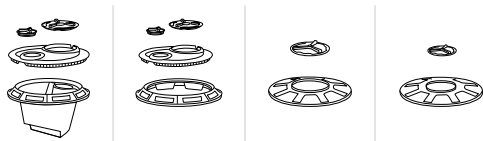

AIS

IMF
DFA

AIN

DEG
SET
FPN
FPAH
DIS

AIC

DEC
SEI

AES

CLY

VOLUMES



1000



1500

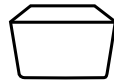

2000

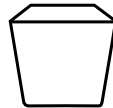

2500

OPTIMIZATION OF TRANSPORT

Sample of Imhoff tanks loading

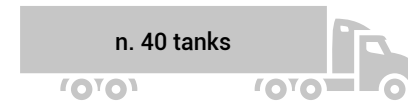

n. 40 tanks

standard
artifacts loading



n. 160 tanks

aurora
artifacts loading

AURORA is a revolutionary modular product, which allows its user, in a few and simple steps, to create the solution for water treatment (primary, secondary, meteoric) and for its collection and storage.

The concept is to have a universal base tank of 4 different sizes, to be selected on the basis of individual need, on which to install a kit of transformation to obtain the various types of purification systems.

Furthermore, the particular conical shape of the tank, allows an optimization and rationalization of transport; indeed, by stacking the tanks, you reach a high containment of space reducing logistics costs that they usually represent a highly penalizing voice compared to the final price.

AIS



icon	model	volume liters	P.E. n.	length		height			inspection			vent	digestion lt	sedimentation lt	€
				Ø ₁ mm	Ø ₂ mm	h max mm	he mm	hu mm	Ø mm	Ø mm	Ø mm				
	IMF AIS 1000 T3	900	5	1.300	1.000	1.160	880	860	400	200	40	620	280	895,00	
	IMF AIS 1500 T3	1.100	7	1.300	850	1.500	1.220	1.190	400	200	40	820	280	1.040,00	
	IMF AIS 2000 T3	1.700	11	1.700	1.400	1.210	880	850	400	200	40	1.300	400	1.520,00	
	IMF AIS 2500 T3	2.250	15	1.700	1.250	1.680	1.360	1.330	400	200	40	1.650	600	2.075,00	

icon	model	volume liters	P.E. n.	length		height			inspection			vent	oxidation lt	sedim. lt	Q air l/min	blower power Watt	diffusers n.	€
				Ø ₁ mm	Ø ₂ mm	h max mm	he mm	hu mm	Ø mm	Ø mm	Ø mm							
	DFA AIS 1000 T4	900	3	1.300	1.000	1.160	880	860	400	200	40	620	280	21	48	2	2.015,00	
	DFA AIS 1500 T4	1.100	4	1.300	850	1.500	1.220	1.190	400	200	40	820	280	29	48	2	2.165,00	
	DFA AIS 2000 T4	1.700	7	1.700	1.400	1.210	880	850	400	200	40	1.300	400	45	48	2	2.785,00	
	DFA AIS 2500 T4	2.250	9	1.700	1.250	1.680	1.360	1.330	400	200	40	1.650	600	58	50	2	3.340,00	

AIN



icon	model	volume liters	P.E. n.	NS lt/sec.	length		height			inspection			vent	greases		inerts		€
					Ø ₁ mm	Ø ₂ mm	h max mm	he mm	hu mm	Ø mm	Ø mm	Ø mm	lt	mm	lt	mm		
	DEG AIN 1000 T3	900	16	2,00	1.300	1.000	1.160	880	860	400	200	40	80	60	200	150	820,00	
	DEG AIN 1500 T3	1.100	22	3,00	1.300	850	1.500	1.220	1.190	400	200	40	120	90	300	225	970,00	
	DEG AIN 2000 T3	1.700	34	4,00	1.700	1.400	1.210	880	850	400	200	40	160	120	400	300	1.445,00	
	DEG AIN 2500 T3	2.250	42	5,50	1.700	1.250	1.680	1.360	1.330	400	200	40	220	125	550	310	1.915,00	

icon	model	volume liters	PE n.	length		height			inspection		vent	€
				Ø ₁ mm	Ø ₂ mm	h max mm	he mm	hu mm	Ø mm	Ø mm	Ø mm	
	SET AIN 1000 T3	900	5	1.300	1.000	1.160	880	860	400	200	40	820,00
	SET AIN 1500 T3	1.100	7	1.300	850	1.500	1.220	1.190	400	200	40	975,00
	SET AIN 2000 T3	1.700	11	1.700	1.400	1.210	880	850	400	200	40	1.450,00
	SET AIN 2500 T3	2.250	15	1.700	1.250	1.680	1.360	1.330	400	200	40	1.915,00

AIN



icon	model	volume liters	P.E. n.	length		height			inspection		vent	filtering mass			€
				∅ ₁ mm	∅ ₂ mm	h max mm	he mm	hu mm	∅ mm	∅ mm	∅ mm	m ²	m	m ³	
	FPN AIN 1000 T3	900	5	1.300	1.000	1.160	880	860	400	200	40	1,10	0,80	0,88	1.520,00
	FPN AIN 1500 T3	1.100	7	1.300	850	1.500	1.220	1.190	400	200	40	1,10	0,95	1,05	1.760,00
	FPN AIN 2000 T3	1.700	11	1.700	1.400	1.210	880	850	400	200	40	2,00	0,80	1,60	2.615,00
	FPN AIN 2500 T3	2.250	14	1.700	1.250	1.680	1.360	1.330	400	200	40	2,00	1,10	2,20	3.265,00

icon	model	volume liters	P.E. n.	length		height			inspection		vent	Q air l/min	blower power Watt	diffusers n.	€
				∅ ₁ mm	∅ ₂ mm	h max mm	he mm	hu mm	∅ mm	∅ mm	∅ mm				
	FPAH AIN 1000 T4	900	4	1.300	1.000	1.160	880	860	400	200	40	21	48	2	2.615,00
	FPAH AIN 1500 T4	1.100	5	1.300	850	1.500	1.220	1.190	400	200	40	29	48	2	2.855,00
	FPAH AIN 2000 T4	1.700	9	1.700	1.400	1.210	880	850	400	200	40	45	48	2	3.865,00
	FPAH AIN 2500 T4	2.250	12	1.700	1.250	1.680	1.360	1.330	400	200	40	58	50	2	4.500,00

icon	model	parking spaces n.	covered square m ²	uncovered square m ²	NS	length		height			inspection		vent	€
						∅ ₁ mm	∅ ₂ mm	h max mm	he mm	hu mm	∅ mm	∅ mm	∅ mm	
	DIS AIN 1000 F	15	700	350	1,5	1.300	1.000	1.160	880	860	400	200	40	795,00
	DIS AIN 1500 F	20	900	450	2,5	1.300	850	1.500	1.220	1.190	400	200	40	945,00
	DIS AIN 2000 F	35	1.400	700	4,0	1.700	1.400	1.210	880	850	400	200	40	1.425,00
	DIS AIN 2500 F	70	2.900	1.450	8,0	1.700	1.250	1.680	1.360	1.330	400	200	40	1.885,00

AES



icon	model	total vol. liters	eff. capacity liters	length		height			inspection		€
				∅ ₁ mm	∅ ₂ mm	h max mm	he mm	hu mm	∅ mm	∅ mm	
	CLY AES 1000	1.000	900	1.300	1.000	1.160	880	860	400	400	505,00
	CLY AES 1500	1.200	1.100	1.300	850	1.500	1.220	1.190	400	400	645,00
	CLY AES 2000	1.850	1.700	1.700	1.400	1.210	880	850	400	400	1.135,00
	CLY AES 2500	2.400	2.250	1.700	1.250	1.680	1.360	1.330	400	400	1.320,00

AIC



icon	model	parking spaces n.	covered square m ²	uncovered square m ²	NS	length		height			inspection		vent	oils volume liters	sediment. volume lt	€
						Ø ₁ mm	Ø ₂ mm	h max mm	he mm	hu mm	Ø mm	Ø mm	Ø mm			
	DEC AIC 1000 AS	15	700	350	1,5	1.300	1.000	1.160	880	860	600	140	1" 1/4	20	200	1.555,00
	DEC AIC 1500 AS	20	900	450	2,5	1.300	850	1.500	1.220	1.190	600	140	1" 1/4	25	250	1.705,00
	DEC AIC 2000 AS	35	1.400	700	4,0	1.700	1.400	1.210	880	850	600	140	1" 1/4	40	400	2.245,00
	DEC AIC 2500 AS	70	2.900	1.450	8,0	1.700	1.250	1.680	1.360	1.330	600	140	1" 1/4	80	800	2.735,00

icon	model	total vol. liters	eff. capacity liters	length		height			inspection	vent	€
				Ø ₁ mm	Ø ₂ mm	h max mm	he mm	hu mm	Ø mm	Ø mm	
	SEI AIC 1000 AG	1.000	900	1.300	1.000	1.160	880	860	400	40	570,00
	SEI AIC 1500 AG	1.200	1.100	1.300	850	1.500	1.220	1.190	400	40	720,00
	SEI AIC 2000 AG	1.850	1.700	1.700	1.400	1.210	880	850	400	40	1.245,00
	SEI AIC 2500 AG	2.400	2.250	1.700	1.250	1.680	1.360	1.330	400	40	1.710,00

BIOLOGICAL | BIOSMART

bismart
BST

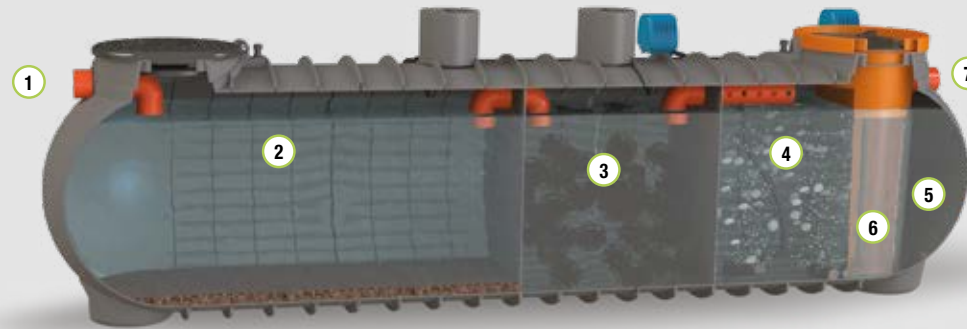

WHERE TO USE IT



INSTALLATION SCHEME

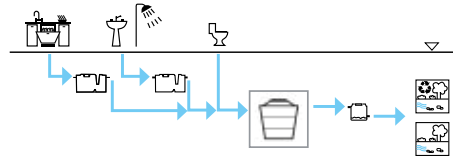

FUNCTION AND USE

The BIOSMART plant is used for the advanced treatment of wastewater from residential buildings and is made with a single artifact. Inside the building there is the primary anaerobic sedimentation section which subsequently conveys the clarified sewage into the percolation area (anoxic area) in which the secondary recirculation is also conveyed. The next step takes place in the floating bed section called MBBR which is a biological reactor inside which the microorganisms, which perform the purification of the wastewater, develop on the surface of special filling bodies arranged in bulk. The further passage of the wastewater in the calm zone allows the collection and sedimentation of the particulate and sends it back via air-lift to the top of the plant. We indicate to convey the wastewater with blonde and gray waters already pre-treated ; for reuse for non-drinking purposes, the use of filtration treatments and final disinfection of the wastewater is indicated.





STANDARDS AND CERTIFICATIONS

EN 12566-3

KEY

- ① Inlet pipe
- ② Primary sedimentation
- ③ Pre-denitrification
- ④ Fluid bed oxidation
- ⑤ Secondary sedimentation
- ⑥ Air-lift recirculation
- ⑦ Outlet pipe

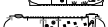
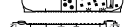
TECHNICAL TABLE - PRICE LIST

icon	model	volume liters	P.E. n.	Le x W x h cm	he / hu cm	Ø pipe in/out mm	caps Ø cm			€
							20	40	60	
vertical artifacts										
	BST AI 2000 RI	1.700	4	170 x 170 x 121	88 / 86	125	1	1	-	9.750,00
	BST AI 2500 RI	2.250	5	170 x 170 x 168	138 / 133	125	1	1	-	11.250,00
modular artifacts										
	BST MP 3700 RI	3.650	8	371 x 125 x 134	118 / 115	125	2	-	2	12.750,00
	BST MP 5000 RI	4.880	10	451 x 125 x 134	118 / 115	125	2	-	2	16.050,00
	BST MP 7000 RI	6.350	12	632 x 125 x 134	118 / 115	125	2	-	2	17.850,00
	BST MM 8500 RI	7.990	16	415 x 176 x 186	157 / 154	160	-	2	2	25.350,00
	BST MM 11000 RI	10.450	20	535 x 176 x 186	157 / 154	160	-	2	2	32.250,00

DEPUR STAR DST

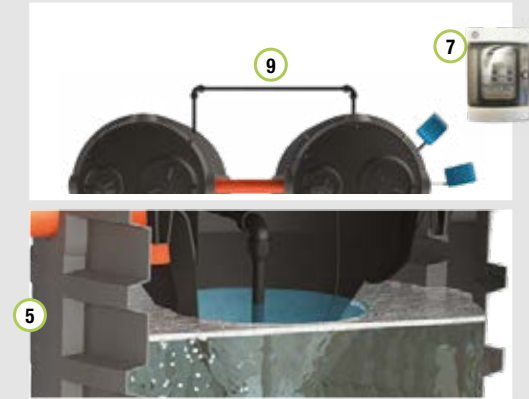
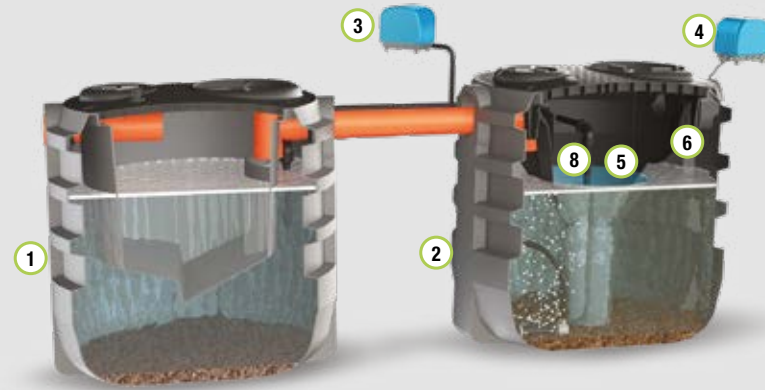

WHERE TO USE IT



INSTALLATION SCHEME

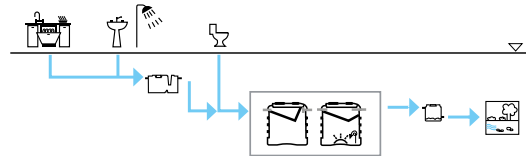

FUNCTION AND USE

The DEPUR STAR plant is used for the advanced treatment of wastewater from residential buildings and is made with two distinct artifacts: Primary sedimentation section using an Imhoff tank and active sludge purification section with truncated conical secondary sedimentation equipped with Thomson type weir, foam guard and sludge recirculation by air-lift. The recirculation will be sent to the primary sedimentation section for the anaerobic digestion of excess sludge. We indicate to convey the wastewater to the plant with blonde and gray waters already pre-treated; for reuse for non-potable purposes the use of any filtration and final disinfection treatments of wastewater is indicated.

STANDARDS AND CERTIFICATIONS

EN 12566-1/3

ADVANTAGES









- Guaranteed purification efficiency*
- Easy-to-run system*
- Minimum maintenance*
- Low energy costs*
- Fully automated*



KEY

- ① Primary treatment
- ② Secondary treatment (active sludge)
- ③ Air compressor diffusers
- ④ Air compressor air-lift recirculation
- ⑤ Sedimentation cone
- ⑥ Thomson Profile with foam protection
- ⑦ Timed control panel
- ⑧ Air-lift recirculation
- ⑨ Recirculation pipe (not supplied)

TECHNICAL TABLE - PRICE LIST

icon	model	volume liters	P.E. n.	Le x W x h cm	he / hu cm	Ø pipe in/out mm	caps Ø cm		€
							20	40	
							n.		
	DST C 800 T4	1.680	2	310 x 130 x 97	78 / 76	125	2	2	4.950,00
	DST C 1200 T4	2.360	4	310 x 130 x 128	108 / 106	125	2	2	5.850,00
	DST CX 2100 T4	4.200	7	350 x 150 x 160	137 / 135	125	2	2	8.400,00
	DST CX 2600 T4	5.200	10	350 x 150 x 182	159 / 157	125	2	2	8.850,00
	DST CS 3500 T4	7.000	12	380 x 165 x 196	175 / 172	160	2	2	9.750,00
	DST CS 4000 T4	8.000	15	440 x 195 x 157	130 / 127	160	-	4	10.950,00
	DST CS 4500 T4	9.000	20	440 x 195 x 178	153 / 150	160	-	4	12.150,00
	DST CS 5100 T4	10.200	25	440 x 195 x 199	172 / 169	160	-	4	12.600,00
	DST CR 5600 T4	11.200	32	510 x 230 x 188	155 / 153	160	-	4	15.600,00
	DST CR 7000 T4	14.000	40	510 x 230 x 218	181 / 179	160	-	4	16.650,00

DEPUR SUPERSTAR DSS

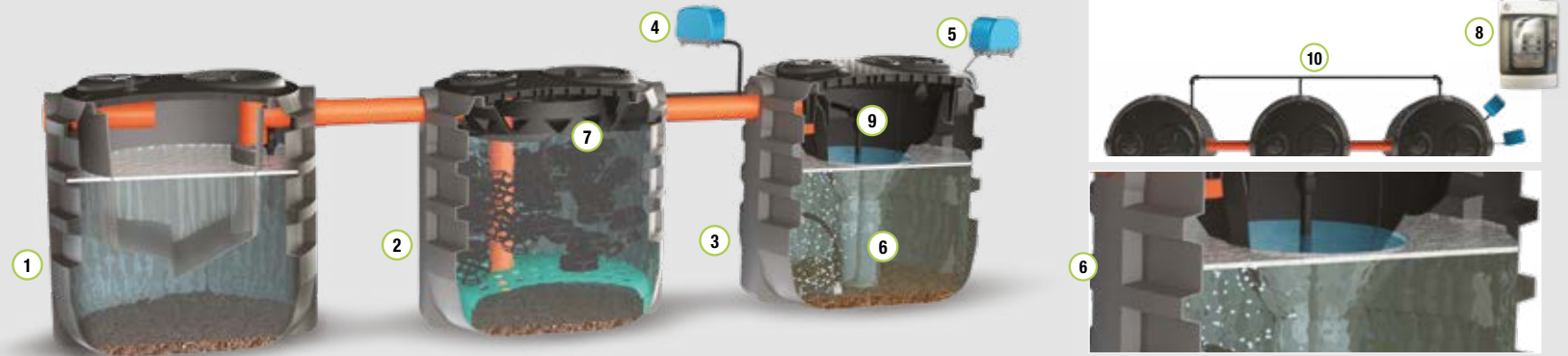

WHERE TO USE IT



INSTALLATION SCHEME

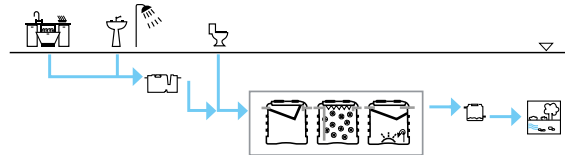

FUNCTION AND USE

The DEPUR SUPERSTAR plant is used for the advanced treatment of wastewater from residential buildings and is made with three distinct artifacts: primary sedimentation section through Imhoff tank, pre-denitrification section (anoxic zone) through trickling filter and active sludge purification section with truncated conical secondary sedimentation equipped with Thomson type weir, foam guard and sludge recirculation by air-lift.

The recirculation will be sent to the pre-denitrification section or to the section of primary sedimentation for anaerobic digestion of excess sludge.

We indicate to convey the wastewater to the plant with yellow and gray waters already pre-treated; for reuse for non-drinking purposes, the use of any filtration treatments and final disinfection of the wastewater is indicated.

STANDARDS AND CERTIFICATIONS

EN 12566-1/3

ADVANTAGES

For a total recovery of waters for irrigation purposes

Maximum guarantee of purification efficiency

Easy-to-run system

Minimum maintenance

Low energy costs











Fully automated



KEY

- ① Primary treatment
- ② Pre-denitrification (trickling filter)
- ③ Secondary treatment (active sludge)
- ④ Air compressor diffuser
- ⑤ Air compressor air-lift recirculation
- ⑥ Secondary sedimentation cone
- ⑦ Thomson Profile with foam protection
- ⑧ Timed control panel
- ⑨ Recirculation air-lift
- ⑩ Recirculation pipe (not supplied)

TECHNICAL TABLE - PRICE LIST

icon	model	volume liters	P.E. n.	Le x W x h cm	he / hu cm	Ø pipe in/out mm	caps Ø cm		€
							20	40	
							n.		
	DSS C 800 RI	2.520	3	490 x 130 x 97	78 / 76	125	3	3	6.675,00
	DSS C 1200 RI	3.540	5	490 x 130 x 128	108 / 106	125	3	3	8.025,00
	DSS CX 2100 RI	6.300	10	550 x 150 x 160	137 / 135	125	3	3	11.850,00
	DSS CX 2600 RI	7.800	14	550 x 150 x 182	159 / 157	125	3	3	12.225,00
	DSS CS 3500 RI	10.500	18	595 x 165 x 196	175 / 172	160	3	3	14.175,00
	DSS CS 4000 RI	12.000	22	685 x 195 x 157	130 / 127	160	-	6	16.200,00
	DSS CS 4500 RI	13.500	28	685 x 195 x 178	153 / 150	160	-	6	17.985,00
	DSS CS 5100 RI	15.300	34	685 x 195 x 199	172 / 169	160	-	6	19.335,00
	DSS CR 5600 RI	16.800	40	790 x 230 x 188	155 / 153	160	-	6	23.775,00
	DSS CR 7000 RI	21.000	44	790 x 230 x 218	181 / 179	160	-	6	24.750,00



RAINWATER TREATMENT

A significant amount of the pollution of the receptor bodies comes from the input of chemical pollution conveyed by the surface runoff waters of urbanized areas. Rains fall on urban surfaces, such as parking lots and squares, from which it removes some of the accumulated material. These are derivatives of fuel combustion, tyre wear, mechanical parts and corrosion of bodyworks that result in highly polluted waters. Discharges from underground parking lots, vehicle repair workshops, car wash centers etc. are equally polluting. Furthermore, overbuilding of the territory (which makes the soil impermeable) leads to increasing in floodings.

DI CAMILLO SERBATOI responds with its own program:

- wide range of solutions for removal of sedimentable solids and light liquids
- rainwater storage and recovery with controlled flow rate (lamination).



CIVIL AND ACTIVITIES



- sand trap
- static oil separator
- coalescence oil separator

RUNOFF WATER



- oil separator with by-pass
- continuous runoff water treatment plant

CAR WASH



- underground car wash plant
- overground car wash plant

LAMINATION



- volano tanks with controlled flow delivery

BYEPLAST



- deplastificatore
Patent n. 10202000013939
del 14/09/2022

SAND TRAP DIS

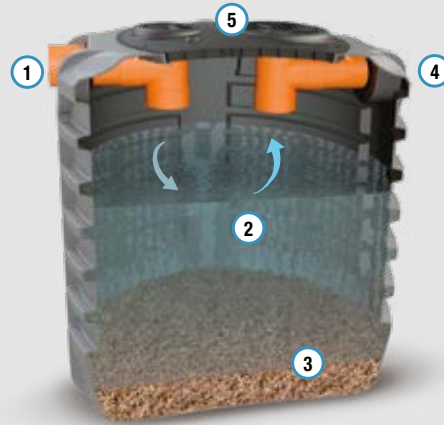

KEY

- ① Inlet pipe
- ② Sedimentation chamber
- ③ Sediments
- ④ Outlet pipe
- ⑤ Reinforced lid (with caps and vent)

WHERE TO USE IT





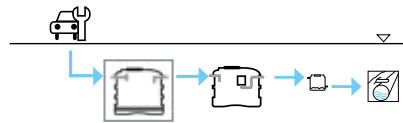











INSTALLATION SCHEME



FUNCTION AND USE

The sand trap is used for the treatment of runoff rainwater from yards and parking lots. It allows the separation of sedimentable material from water. It is basically a settling tank in which runoff waters flowing on road surfaces are purified from the sedimentable material, which remains on the bottom of the tank.

TECHNICAL TABLE - PRICE LIST

icon	model	NS	parking spaces	covered square	uncovered square	oils volume	Le x W x h cm	he / hu cm	Ø pipe in/out mm	caps Ø cm			€
			n.	m ²	m ²	liters				20	40	60	
	DIS L 500 F	1,0	5	370	190	450	80 x 80 x 116	99 / 97	125	-	1	-	525,00
	DIS C 800 F	2,0	15	730	370	840	130 x 130 x 97	78 / 76	125	1	1	-	745,00
	DIS C 1200 F	3,0	25	1.100	550	1.180	130 x 130 x 128	108 / 106	125	1	1	-	915,00
	DIS C 1600 F	4,0	35	1.460	730	1.680	130 x 130 x 172	153 / 151	125	1	1	-	1.230,00
	DIS C 2000 F	6,0	50	2.190	1.100	1.920	130 x 130 x 194	175 / 173	125	1	1	-	1.455,00
	DIS CX 2100 F	8,0	70	2.910	1.460	2.100	150 x 150 x 160	137 / 135	160	1	1	-	1.735,00
	DIS CX 2600 F	11,0	90	3.640	1.820	2.600	150 x 150 x 182	159 / 157	160	1	1	-	2.205,00
	DIS CS 3000 F	12,0	105	4.370	2.190	3.020	165 x 165 x 173	155 / 152	200	1	1	-	2.385,00
	DIS CS 3500 F	14,0	125	5.100	2.550	3.500	165 x 165 x 196	175 / 172	200	1	1	-	2.920,00
	DIS CS 4000 F	16,0	145	5.820	2.910	4.000	195 x 195 x 157	130 / 127	200	-	2	-	3.075,00
	DIS CS 4500 F	18,0	160	6.550	3.280	4.500	195 x 195 x 178	153 / 150	200	-	2	-	3.390,00
	DIS CS 5100 F	20,0	180	7.280	3.640	5.100	195 x 195 x 199	172 / 169	200	-	2	-	3.780,00
	DIS CR 5600 F	22,0	200	8.000	4.000	5.600	230 x 230 x 188	155 / 153	250	-	2	-	4.080,00
	DIS CR 7000 F	30,0	270	10.910	5.460	7.000	230 x 230 x 218	181 / 179	250	-	2	1	4.650,00
	DIS N 9000 F	36,0	325	13.100	6.550	7.520	285 x 210 x 234	195 / 192	315	-	-	-	5.830,00

STATIC OIL SEPARATOR DEO

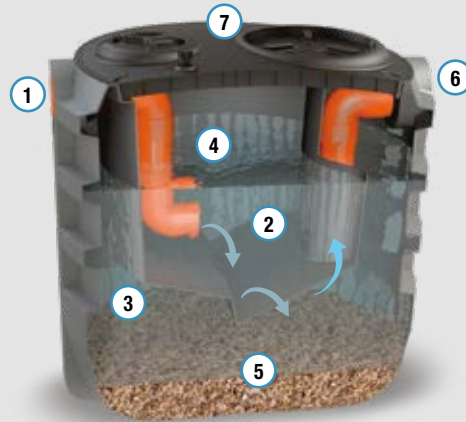

KEY

- ① Inlet pipe
- ② Light liquids separation chamber
- ③ Sedimentation chamber
- ④ Separated light liquids
- ⑤ Sediments
- ⑥ Outlet pipe
- ⑦ Reinforced lid (with caps and vent)

WHERE TO USE IT



INSTALLATION SCHEME

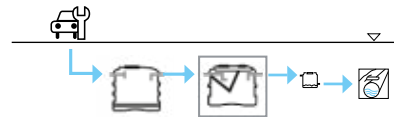













FUNCTION AND USE

The static oil separator is used for the treatment of runoff rainwater from yards and parking lots or from activities such as garages, body shops, etc. which discharge into public sewer. It removes the masses of floating material produced by the combination of oils and greases: it is basically a settling tank in which runoff waters flowing on impermeable surfaces are purified both from the floating material at the top and from the sedimentable material which remains on the bottom of the tank.

STANDARDS AND CERTIFICATIONS

EN 858/1-2
Class II

TECHNICAL TABLE - PRICE LIST

icon	model	NS	parking spaces m ²	covered square m ²	uncovered square n.	volume liters	Le x W x h cm	he / hu cm	Ø pipe in/out mm	caps Ø cm		€
										20	40	
										n.		
	DEO C 800 F	2	370	730	15	840	130 x 130 x 97	78 / 76	125	1	1	915,00
	DEO C 1200 F	3	550	1.100	25	1.180	130 x 130 x 128	108 / 106	125	1	1	1.215,00
	DEO C 1600 F	4	730	1.460	35	1.680	130 x 130 x 172	153 / 151	125	1	1	1.575,00
	DEO C 2000 F	6	1.100	2.190	50	1.920	130 x 130 x 194	175 / 173	125	1	1	1.935,00
	DEO CX 2100 F	8	1.460	2.910	70	2.100	150 x 150 x 160	137 / 135	160	1	1	2.205,00
	DEO CX 2600 F	10	1.820	3.640	90	2.600	150 x 150 x 182	159 / 157	160	1	1	2.580,00
	DEO CS 3000 F	12	2.190	4.370	105	3.020	165 x 165 x 173	155 / 152	200	1	1	2.970,00
	DEO CS 3500 F	14	2.550	5.100	125	3.500	165 x 165 x 196	175 / 172	200	1	1	3.360,00
	DEO CS 4000 F	16	2.910	5.820	145	4.000	195 x 195 x 157	130 / 127	200	-	2	3.705,00
	DEO CS 4500 F	20	3.640	7.280	180	4.500	195 x 195 x 178	153 / 150	200	-	2	4.335,00
	DEO CS 5100 F	22	4.000	8.000	200	5.100	195 x 195 x 199	172 / 169	250	-	2	4.875,00
	DEO CR 5600 F	26	4.730	9.460	235	5.600	230 x 230 x 188	155 / 153	250	-	2	5.805,00
	DEO CR 7000 F	30	5.460	10.910	270	7.000	230 x 230 x 218	181 / 179	250	-	2	6.015,00

COALESCENCE OIL SEPARATOR DEC

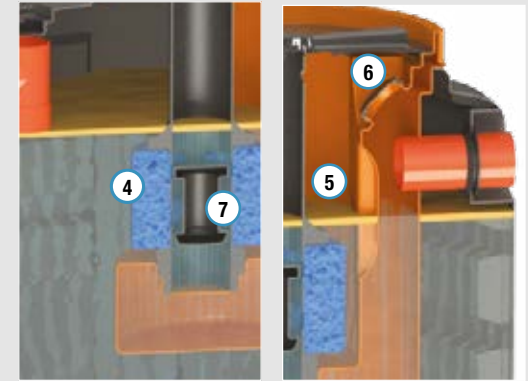
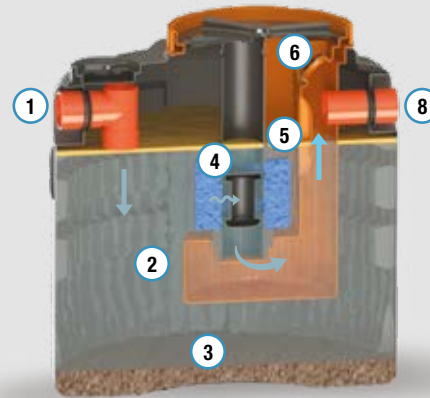

WHERE TO USE IT



INSTALLATION SCHEME

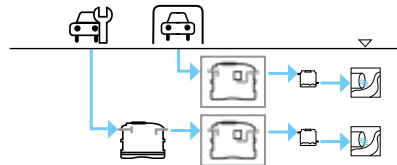

FUNCTION AND USE

The coalescence oil separator is used for the treatment of runoff rainwater from garages, car washes, fuel depots, fuel distributors and garages. It is a plant designed according to the UNI EN 858-1 2005 standard for the separation of gasolines, oils, greases and other light fractions of petroleum products. It is equipped with a special polyurethane foam filter with high specific surface which, by increasing the effective flotation surface, favors the aggregation of the lighter particles and facilitates their ascent: in this way the separation efficiency increases and the dimensions can be reduced compared to the larger gravity separators. Oil separation is usually achieved by reducing the speed of the influent and arranging a settling zone in which the substances present, characterized by a specific weight lower than that of water, float up.

















STANDARDS AND CERTIFICATIONS

EN 858/1-2
Class I

KEY

- ① Inlet pipe
- ② Sedimentation chamber
- ③ Sediments
- ④ Coalescence filtration
- ⑤ Light liquids separation
- ⑥ Outlet duct inspection
- ⑦ Float shutter
- ⑧ Purified sewage outlet

TECHNICAL TABLE - PRICE LIST

icon	model	NS	parking space n.	covered square m ²	uncovered square m ²	volume liters	Le x W x h cm	he / hu cm	Ø pipe in/out mm	caps Ø cm			€
										20	40	60	
	DEC O 200 AS	1,0	5	370	190	200	60 x 60 x 80	64 / 62	110	-	1	-	1.500,00
	DEC CC 800 AS	2,0	15	730	370	840	130 x 130 x 110	78 / 76	125	1	-	1	1.815,00
	DEC CC 1200 AS	3,0	25	1.100	550	1.180	130 x 130 x 140	108 / 106	125	1	-	1	1.975,00
	DEC CC 1600 AS	4,0	35	1.460	730	1.680	130 x 130 x 185	153 / 151	125	1	-	1	2.160,00
	DEC CC 2000 AS	6,0	50	2.190	1.100	1.920	130 x 130 x 207	175 / 173	125	1	-	1	2.520,00
	DEC CC 2100 AS	8,0	70	2.910	1.460	2.100	150 x 150 x 177	137 / 135	160	1	-	1	2.980,00
	DEC CC 2600 AS	10,0	90	3.640	1.820	2.600	150 x 150 x 194	157 / 155	160	1	-	1	3.465,00
	DEC CC 3000 AS	15,0	135	5.460	2.730	3.000	165 x 165 x 186	161 / 159	200	1	-	1	3.750,00
	DEC CC 3500 AS	18,0	160	6.550	3.280	3.500	165 x 165 x 208	179 / 176	200	1	-	1	4.410,00
	DEC CS 4000 AS	20,0	180	7.280	3.640	4.000	195 x 195 x 166	130 / 127	200	-	1	1	4.650,00
	DEC CS 4500 AS	24,0	215	8.730	4.370	4.500	195 x 195 x 187	153 / 150	250	-	1	1	5.125,00
	DEC CS 5000 AS	30,0	270	10.910	5.460	5.100	195 x 195 x 208	172 / 169	250	-	1	1	6.070,00
	DEC CR 5600 AS	32,0	290	11.640	5.820	5.600	230 x 230 x 197	156 / 154	250	-	1	1	6.750,00
	DEC MM 7500 AS	38,0	345	13.820	6.910	6.740	355 x 176 x 186	157 / 154	315	-	-	2	8.905,00
	DEC CR 7000 AS	40,0	360	14.550	7.280	7.000	230 x 230 x 227	186 / 184	250	-	1	1	7.500,00
	DEC N 9000 AS	50,0	450	18.190	9.100	7.520	285 x 210 x 234	195 / 192	315	-	-	1	9.595,00

UNDERGROUND CAR WASH PLANT IAL I



WHERE TO USE IT



INSTALLATION SCHEME

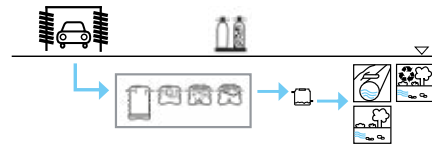

FUNCTION AND USE

The plant is used for the treatment of water coming from car wash plants. This plant is made up of a pre-treatment phase in which the separation of solids and oils takes place by gravity (sand trap and oil separator), a phase of biological treatment by means of aerated biofiltration and a final sedimentation phase. The inlet flow rate of the system must never exceed the rated flow rate. It is advisable to feed the system with a constant flow if possible. With the addition of a final pressure filtration section composed of a quartzite filter and an active carbon filter, it is possible to reuse the water for the first washing phases only.

STANDARDS AND CERTIFICATIONS

EN 858/1-2
EN 12566 1-3

KEY

- Ⓐ Sand trap
- Ⓑ Coalescence oil separator
- Ⓒ Aerated biofilter and sedimentation
- Ⓓ Relaunching to final filtration
- Ⓔ Sand and active carbon filtration skid (automatic or manual)

TECHNICAL TABLE - PRICE LIST

icon	model	cars/day n.	Q max liters/h	volume liters	Le x W x h cm	caps Ø cm			€
						20	40	60	
	IAL I 200 F	10	200	2.860	490 x 130 x 128	3	2	1	4.875,00
	IAL I 400 F	20	400	5.360	510 x 150 x 182	3	2	1	6.165,00
	IAL I 600 F	30	600	5.960	510 x 150 x 182	3	2	1	7.125,00
	IAL I 1000 F	50	1.000	8.200	565 x 165 x 197	2	3	1	10.155,00
	IAL I 1500 F	80	1.500	11.700	645 x 230 x 197	1	4	1	12.745,00
	IAL I 2300 F	100	2.300	16.100	725 x 230 x 218	1	4	1	17.725,00

icon	model	cars/day n.	Q max liters/h	volume liters	Le x W x h cm	caps Ø cm			with automatic skid	with manual skid
						20	40	60	€	€
	IAL I 200 RI	10	200	3.910	670 x 130 x 128	3	2	1	15.950,00	14.810,00
	IAL I 400 RI	20	400	5.330	690 x 165 x 182	3	2	1	18.140,00	17.045,00
	IAL I 600 RI	30	600	7.010	690 x 150 x 182	3	2	1	24.470,00	23.215,00
	IAL I 1000 RI	50	1.000	9.250	745 x 165 x 197	2	3	1	30.990,00	28.795,00
	IAL I 1500 RI	80	1.500	12.750	825 x 230 x 197	1	4	1	39.615,00	-
	IAL I 2300 RI	100	2.300	17.150	905 x 230 x 218	1	4	1	51.685,00	47.730,00

For this type of system it is necessary to provide a backwash line for the filtration system with a pressure suitable for use (see instruction booklet supplied with the items).
The backwash discharge must be conveyed to the head of the plant or to the Public Sewer with prior authorization from the competent body.

F: DISCHARGE
RI: WATER REUSE

The system must be powered possibly at a constant flow rate which must never exceed the maximum rated flow rate.

OVERGROUND CAR WASH PLANT

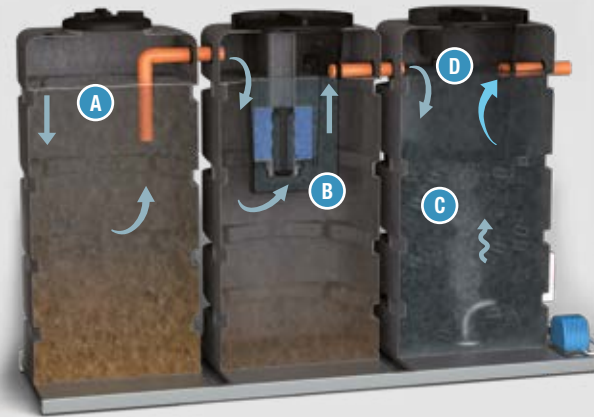

KEY

- (A) Sand trap
- (B) Coalescence oil separator
- (C) Aerated biofiltration
- (D) Final sedimentation
- (E) Sand and active carbon filtration skid (automatic or manual)

WHERE TO USE IT



The plant is used for the treatment of water coming from manual car wash plants or from small portals and tunnels.

INSTALLATION SCHEME

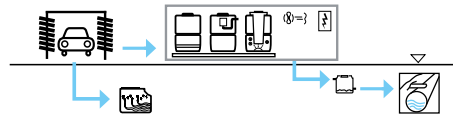

FUNCTION AND USE

The plant is used for the treatment of water coming from car wash plants. This plant is made up of a pre-treatment phase in which the separation of solids and oils takes place by gravity (sand trap and oil separator), a phase of biological treatment by means of aerated biofiltration and a final phase of sedimentation.





The system must be fed at a constant flow rate, which must never exceed the maximum rated capacity, using a pump not included in the supply. With the addition of a final pressure filtration section composed by a quartzite filter and an active carbon filter, it is possible to reuse the water for the first washing phases only.



STANDARDS AND CERTIFICATIONS

EN 858/1-2

EN 12566-1/3

TECHNICAL TABLE - PRICE LIST

icon	model	cars/day n.	Q max liters/h	volume m ²	Le x W x h cm	caps Ø cm				€
						14	20	40	60	
						n.				
	IALE 1500 F	10	100	1.500	240 x 67 x 131	-	-	1	2	4.055,00
	IALE 2250 F	15	150	2.250	240 x 67 x 206	-	-	1	2	4.625,00
	IALE 3000 F	20	200	3.000	326 x 95 x 161	-	-	1	2	6.185,00
	IALE 4500 F	25	250	4.500	326 x 95 x 207	-	-	1	2	7.035,00

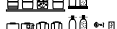
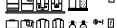
icon	model	cars/day n.	Q max liters/h	volume m ²	Le x W x h cm	caps Ø cm				with automatic skid	with manual skid
						14	20	40	60	€	€
						n.					
	IALE 1500 RI	10	100	2.000	296 x 67 x 131	-	-	1	3	14.420,00	13.280,00
	IALE 2250 RI	15	150	3.000	296 x 67 x 206	-	-	1	3	15.150,00	14.010,00
	IALE 3000 RI	20	200	4.000	382 x 95 x 161	-	-	1	3	16.960,00	15.820,00
	IALE 4500 RI	25	250	5.000	382 x 95 x 207	-	-	1	3	18.060,00	16.910,00

For this type of system it is necessary to provide a backwash line for the filtration system with a pressure suitable for use (see instruction booklet supplied with the items). The backwash discharge must be conveyed to the head of the plant or to the Public Sewer with prior authorization from the competent body.

F: DISCHARGE
RI: WATER REUSE

The system must be powered possibly at a constant flow rate which must never exceed the maximum rated flow rate.

RAINWATER TREATMENT | RUNOFF WATER

CONTINUOUS RUNOFF WATER TREATMENT PLANT IPC



KEY

- A** Spillway
- B** Sand trap chamber
- C** Oil separation chamber with coalescence system
- D** Float shutter

WHERE TO USE IT



INSTALLATION SCHEME

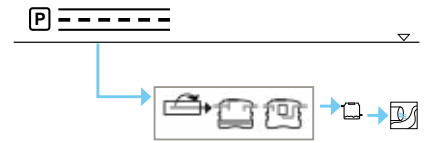

FUNCTION AND USE

The continuous runoff rainwater treatment plant is used to remove the pollutants present in the surface waters flowing on urbanized areas, which are the main causes of poor water quality, and is sized according to the provisions of the UNI-EN 858-1/2 standards. It consists of one by-pass spillway for peak flows and physical separation treatments of sand removal and oil separation via coalescence filtration. This plant, instead of treating only the 5 mm of first rain, it is sized for multiples of flow rate, thus treating a fixed fraction of rain. Such an approach allows to significantly contain the total amount of oily pollutants poured into the receptor body compared to the traditional setting. Concentrations of pollutants considered at the entrance of the plant are those typical of a runoff waste water from a waterproof yard not containing dangerous substances nor concentrations of heavy metals or other pollutants other than SST and total hydrocarbons above the thresholds set by the reference tables for discharge into Surface Waters.

STANDARDS AND CERTIFICATIONS

EN 858/1-2

TECHNICAL TABLE - PRICE LIST

icon	model	NS	uncovered square m ²	total useful volume liters	Le x W x h cm	he / hu cm	caps cm		caps Ø cm			€
							50x50	20	40	60		
	IPC C 800 AS	2	360	1.680	464 x 130 x 110	78 / 76	1	2	1	1	3.300,00	
	IPC C 1200 AS	3	450	2.360	464 x 130 x 140	108 / 106	1	2	1	1	3.600,00	
	IPC C 1600 AS	4	720	3.360	464 x 130 x 185	153 / 151	1	2	1	1	4.050,00	
	IPC C 2000 AS	6	1.090	3.840	464 x 130 x 207	175 / 173	1	2	1	1	4.650,00	
	IPC C 2100 AS	8	1.450	4.200	504 x 150 x 172	137 / 135	1	2	1	1	5.850,00	
	IPC C 2600 AS	10	1.810	5.200	504 x 150 x 194	157 / 155	1	2	1	1	7.050,00	
	IPC C 3000 AS	12	2.180	6.040	608 x 165 x 186	161 / 159	-	1	2	2	7.500,00	
	IPC C 3500 AS	15	2.720	7.000	608 x 165 x 208	179 / 176	-	1	2	2	7.950,00	
	IPC C 4000 AS	20	3.630	8.000	668 x 195 x 166	130 / 127	-	-	3	2	8.850,00	
	IPC C 4500 AS	25	4.540	9.000	668 x 195 x 187	153 / 150	-	-	3	2	10.050,00	
	IPC C 5100 AS	30	5.450	10.200	668 x 195 x 208	172 / 169	-	-	3	2	10.800,00	
	IPC C 5600 AS	35	6.360	11.200	738 x 230 x 190	156 / 154	-	-	3	2	14.100,00	
	IPC C 7000 AS	40	7.270	14.000	738 x 230 x 227	186 / 184	-	-	3	2	15.750,00	
	IPC N 9000 AS	50	9.090	15.040	848 x 210 x 234	195 / 192	-	-	-	3	17.550,00	
	IPC M 18000 AS	60	10.900	17.650	848 x 210 x 234	206 / 201	-	-	-	4	23.250,00	
	IPC M 24000 AS	80	14.540	23.420	1.028 x 210 x 234	206 / 201	-	-	2	5	28.200,00	
	IPC M 30000 AS	100	18.180	29.220	1.208 x 210 x 234	206 / 201	-	-	3	6	36.000,00	
	IPC M 36000 AS	120	21.810	35.060	1.388 x 210 x 234	206 / 201	-	-	-	7	40.500,00	
	IPC M 42000 AS	140	25.450	40.730	1.568 x 210 x 234	206 / 201	-	-	-	8	48.150,00	

CONTINUOUS RUNOFF WATERS TREATMENT PLANT OIL SEPARATOR WITH INTEGRATED BY-PASS DEC CB / MB

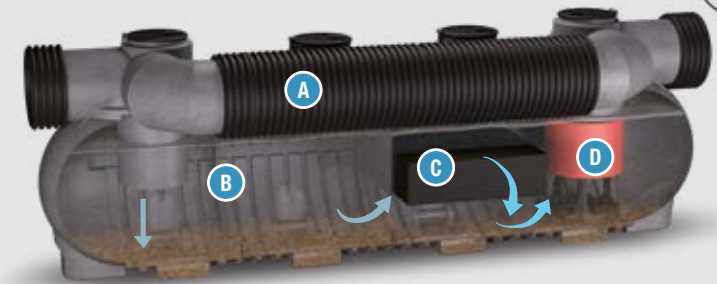
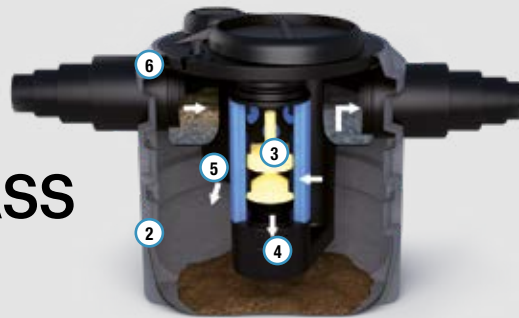

WHERE TO USE IT



INSTALLATION SCHEME

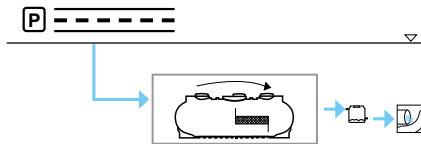

FUNCTION AND USE

The oil separator with integrated by-pass is used to remove the pollutants present in the surface waters flowing on urbanized areas, which are the main causes of poor water quality. In fact, meteoric water, when comes into contact with urban surfaces, removes the material accumulated during dry periods and causes the typical pollution of the so-called runoff water on impermeable surfaces (yards, roads, parking lots, etc.) from which these pollutants must be removed through physical separation plants.

The tank includes a three-way spillway, inserted directly on the product, suitable for separating the flow exceeding the maximum of treatment and directly connected to the outlet duct. It is internally divided into two sections: sand removal chamber for the removal of sedimentable particles and oil separation chamber with coalescence filters for the separation and removal of light liquids. Concentrations of pollutants considered at the entrance of the plant are those typical of a runoff waste water from a waterproof yard not containing dangerous substances nor concentrations of heavy metals or other pollutants other than SST and total hydrocarbons above the thresholds set by the reference tables for discharge into Surface Waters.

STANDARDS AND CERTIFICATIONS

EN 858/1-2

KEY

- ① Inlet pipe
- ② Sand trap
- ③ Coalescence filter
- ④ Outlet duct
- ⑤ Float shutter
- ⑥ By-pass channel

- A By-pass
- B Sand trap
- C Oil separation
- D Float shutter

TECHNICAL TABLE - PRICE LIST

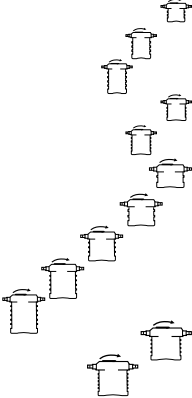
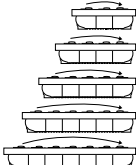
icon	model	spillway		parking spaces n.	uncovered square m ²	Le x W x h cm	he / hu cm	caps cm		caps Ø cm		€
		NS	max. flow rate l/s					50x50 n.	20	40	60	
	DEC CB 1200 AS	4	20	30	720	130 x 130 x 132	98 / 95	160÷315	1	-	1	2.445,00
	DEC CB 1600 AS	6	30	50	1.090	130 x 130 x 176	142 / 139	160÷315	1	-	1	2.775,00
	DEC CB 2000 AS	7	35	60	1.270	130 x 130 x 198	164 / 161	160÷315	1	-	1	3.780,00
	DEC CB 2100 AS	8	40	70	1.450	150 x 150 x 163	132 / 129	160÷315	1	-	1	4.020,00
	DEC CB 2600 AS	10	50	90	1.810	150 x 150 x 185	152 / 150	160÷315	1	-	1	4.335,00
	DEC CB 3000 AS	12	60	100	2.180	165 x 165 x 173	148 / 145	160÷315	1	-	1	4.480,00
	DEC CB 3500 AS	15	75	130	2.720	165 x 165 x 196	170 / 167	160÷315	1	-	1	4.855,00
	DEC CB 4000 AS	20	100	180	3.630	195 x 195 x 157	114 / 111	160÷400	-	1	1	5.325,00
	DEC CB 4500 AS	25	125	220	4.540	195 x 195 x 178	137 / 134	160÷400	-	1	1	6.085,00
	DEC CB 5100 AS	30	150	270	5.450	195 x 195 x 199	158 / 155	160÷400	-	1	1	7.125,00
	DEC CB 5600 AS	35	175	310	6.360	230 x 230 x 188	142 / 139	160÷400	-	1	1	8.640,00
	DEC CB 7000 AS	45	225	400	8.180	230 x 230 x 218	186 / 187	160÷400	-	1	1	9.345,00
	DEC MB 18000 AS	80	400	-	14.540	633 x 250 x 275	220 / 215	600	-	-	3	37.500,00
	DEC MB 24000 AS	100	500	-	18.180	813 x 250 x 275	220 / 215	600	-	-	4	42.000,00
	DEC MB 30000 AS	130	650	-	23.630	993 x 250 x 275	220 / 215	800	-	-	5	49.500,00
	DEC MB 36000 AS	160	800	-	29.090	1.173 x 250 x 275	220 / 215	800	-	-	6	58.500,00
	DEC MB 42000 AS	200	1.000	-	36.360	1.353 x 250 x 275	220 / 215	800	-	-	7	63.000,00

LAMINATION

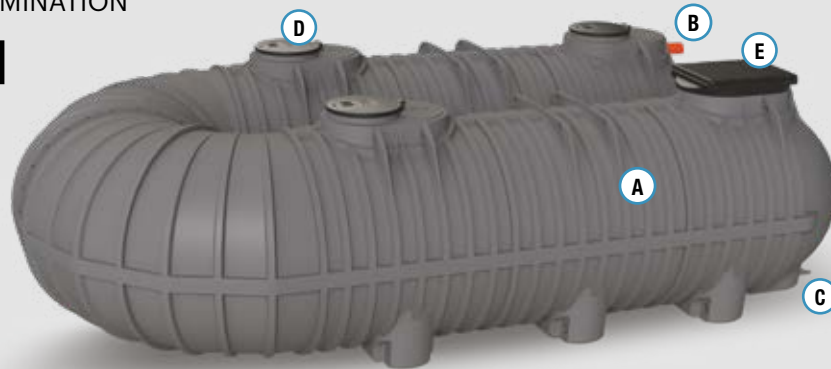

KEY

- A** Storage tank
- B** Inlet
- C** Outlet
- D** Manhole inspection Ø 600
- E** Rectangular inspection 800x1200

WHERE TO USE IT



INSTALLATION SCHEME

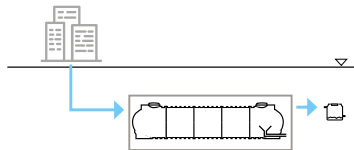

FUNCTION AND USE

Lamination tanks are realized with polyethylene tanks, with function of collecting rainwater (generally large volumes) coming from the runoff of urbanized surfaces to then be released at a controlled rate. This allows to maintain the hydraulic and hydrological invariance of the final receptor (sewer, ditch, stream, etc.). Inside the tank there is a system for regulating the outgoing flow rate which can be realized with special pipes with calibrated diameter according to the maximum flow rate to be returned to the receptor or with a pumping system equipped with gate valves which allow the control of the outgoing flow rate. In the case of flow rate return system made by means of a submersible electric pump, everything is controlled and commanded automatically by level switches and by an electronic panel which also performs the function of electrical protection and eventual alarm.

PLANT COMPOSITION

- A** Storage tank
- B** Inlet
- C** Outlet:
 - C1** ① Outlet with calibrated pipe
② Manhole inspection
 - C2** Outlet with calibrated pipe (see C1) complete with:
 - ③ Rectangular inspection
 - ④ Solids treatment grid
 - ⑤ Emergency spillway
 - ⑥ High level visual indicator
 - C3** Outlet with booster pump complete with:
 - ⑦ Manual regulation of the flow rate
 - ⑧ Ball check valve
 - ② Manhole inspection
 - ⑨ Emergency overflow
 ADD PRICE
(same diameter of B)
Electric panel OPTIONAL

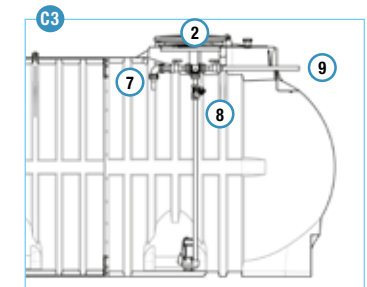
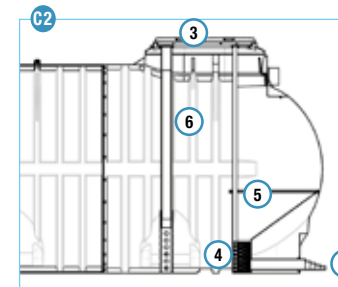
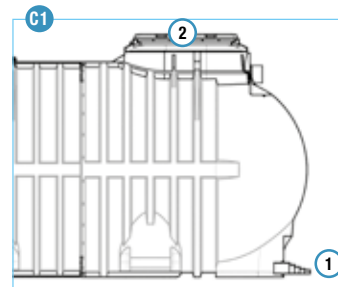
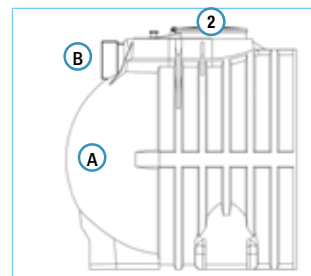

A STORAGE TANK

choose the tank	icon	model	total volume	Le x W x h	caps Ø 60	€
			liters	cm	n.	
<input type="checkbox"/>		SEI M 12000 LAM	12.750	440 x 210 x 234	2	8.100,00
<input type="checkbox"/>		SEI M 18000 LAM	18.980	620 x 210 x 234	2	12.900,00
<input type="checkbox"/>		SEI M 24000 LAM	25.200	800 x 210 x 234	2	16.350,00
<input type="checkbox"/>		SEI M 30000 LAM	31.420	980 x 210 x 234	2	20.250,00
<input type="checkbox"/>		SEI M 36000 LAM	37.650	1.160 x 210 x 234	2	25.200,00
<input type="checkbox"/>		SEI M 42000 LAM	43.870	1.340 x 210 x 234	2	31.800,00
<input type="checkbox"/>		SEI MCU 72000 LAM	72.000	1.170 x 461 x 232	7	41.700,00
<input type="checkbox"/>		SEI MCU 84000 LAM	84.000	1.350 x 461 x 232	8	50.850,00
<input type="checkbox"/>		SEI MCC 114000 LAM	114.000	1.000 x 1001 x 232	5	73.800,00
<input type="checkbox"/>		SEI MCC 126000 LAM	126.000	1.180 x 1001 x 232	9	93.450,00
<input type="checkbox"/>		SEI MCC 162000 LAM	162.000	1.360 x 1001 x 232	9	114.000,00

B INLET

choose the inlet pipe	Ø pipes	maximum flow rate	€
	mm	liters/s	
<input type="checkbox"/>	200	20	100,00
<input type="checkbox"/>	250	30	115,00
<input type="checkbox"/>	315	100	160,00
<input type="checkbox"/>	450	150÷300	180,00
<input type="checkbox"/>	630	300÷400	250,00

C OUTLET

choose the outlet type	Ø pipes	maximum flow rate	€
	mm	liters/s	

C1 CALIBRATED OUTLET PIPE

<input type="checkbox"/>	30	2	60,00
<input type="checkbox"/>	40	4	60,00
<input type="checkbox"/>	60	8	60,00
<input type="checkbox"/>	80	16	60,00
<input type="checkbox"/>	100	24	60,00

C2 BOOSTER PUMP

model	power	flow rate	head	€
	kW	liters/min	m	
KIT Z EQU037	0,37	0-250	8-0,8	910,00

C3 EMERGENCY SPILLWAY KIT

model	Ø float	Ø grid spacing	€
	mm	mm	
KIT LAM OUT	63	5	1.800,00

Photocopy and fill in putting an **X** on the requested type. For any information you can contact our technical office at the number



RAINWATER TREATMENT

BYEplast

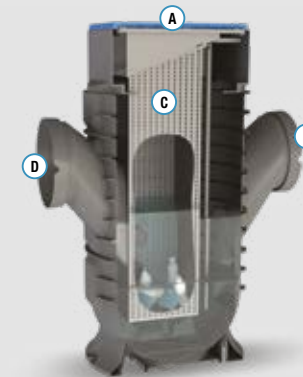
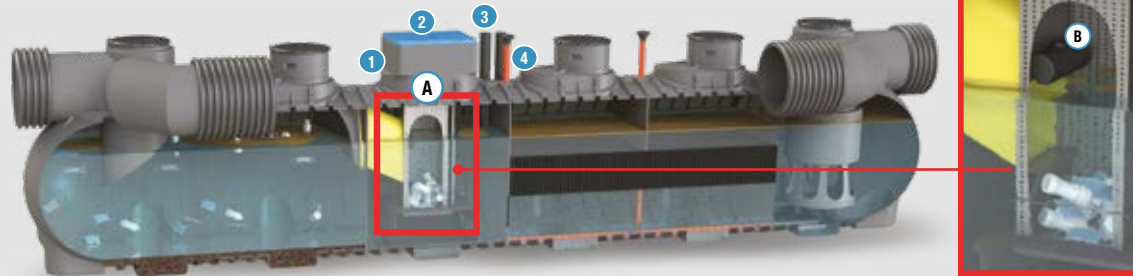

KEY

- (A)** Byeplast device
- (B)** Gate with float
- (C)** Basket closure
- (D)** Plastic trap basket
- (E)** Inlet
- (F)** Outlet
- (1)** Inspection turret
- (2)** Anti-intrusion grid
- (3)** Suction pipe
- (4)** Still-pipe

WHERE TO USE IT



INSTALLATION SCHEME

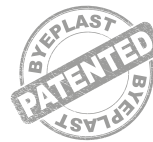

PATENT
n. 10202000013939
del 14/09/2022



FUNCTION AND USE

The module DEPLASTIFICATORE BYEPLAST is a device that prevents plastics contained in the runoff water from reaching and flowing into water bodies (plastic bags, bottles, cans, etc...). This device can also be implemented within a continuous treatment system of runoff water (sand and oil separation) or used as a specific treatment inside a separate tank placed upstream of a lamination plant.

It is equipped with an easily removable stainless steel plastic trap basket with extraction guide pipes and shaped support placed on the bottom.

The opening of the trap basket is automatically closed by means of a polyethylene gate equipped with a float that changes its position according to liquid level.

BYEplast



- Environmentally friendly*
- Reusable*
- Prevents plastics from polluting rivers and seas*
- Reduced conduction*
- Reduced maintenance*
- Plastic-Free Service*

FUNCTIONING KEY

- 1** BYEplast recently installed. The basket is still empty and the runoff rainwater to be treated is flowing without obstacles.
- 2** BYEplast in function. Suspended plastics and solid materials present in runoff waters are caught inside the trap basket.
- 3** Full BYEplast. The material trapped inside the basket precludes the total and correct transition of water downstream, causing the raising of the liquid level upstream: it is then necessary the maintenance of the system through the substitution of the basket with an empty one and the consequent transport of the collected material to an appropriate authorized landfill.

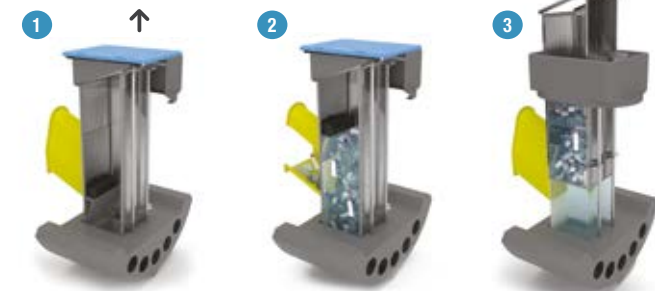





TECHNICAL TABLE - PRICE LIST

icon	model	retention tank			basket			inlet gate		Ø guide pipes mm	€
		Le	W	x h	Le	W	x h	Le	x h		
		cm			cm			cm			
	BYE Y 550 MXS	196	125	x 257	55	55	x 210	120	x 80	32	11.250,00
	BYE Y 550 MB	180	210	x 234	55	55	x 210	120	x 80	32	6.075,00*

* BYEplast module only

ACCESSORIES | TECHNICAL TABLE - PRICE LIST

icon	model	description	Le x W x h	€
			cm	
	G PRO MD X 1200-50	Inspection turret	120 x 80 x 50	585,00
	H GRA Y 40-80 AC	Rectangular shaped anti-intrusion grid	40 x 80	440,00
	I TUBY 110 BYE	Suction pipe for cleaning the bottom of the tank	Ø 110 x 250	200,00
	L TUBY 063 BYE	Still-pipe for level sensors entry	Ø 63 x 150	130,00

BOX FOR "TRAP BASKET" TRANSPORT



ACCESSORY FOR MAINTENANCE

- Plastic trap basket removal
- New basket installation
- Trap basket transport to disposal center
- Empty trap basket positioning inside the box for transport

APPLICATIONS

INSTALLATION TYPE

The ByePlast device can be used in the following plants:

- LAM ..** lamination tanks
- IPPA ..** first-rain storage treatment plant
- IPC ..** continuous runoff water treatment plant
- DEC MB ..** continuous rainwater treatment plant with by-pass



BYEplast integrated on runoff water treatment plants



BYEplast supplied as single system, to be installed on new or pre-existing sewer lines for white water



WATER RECOVERY

Fresh water resource on earth represents a very small percentage of all water present on the planet. Climate change, waste of water and leakages of the aqueducts, affect the availability of drinking water resources.

Furthermore, energy costs for pumping, transport and purification are extremely high.

For these reasons, the cost of drinking water will grow in the next few years with even double-digit percentages.

In order to face such problem, DI CAMILLO SERBATOI has adopted the motto "save your blue gold" by proposing various system solutions.

It is therefore essential to provide adequate systems inside buildings that allow drinking water saving and reuse of less valuable water (rainwater and grey water), which can be used for services that do not require potable water and bring a consumption saving even higher than 50%.

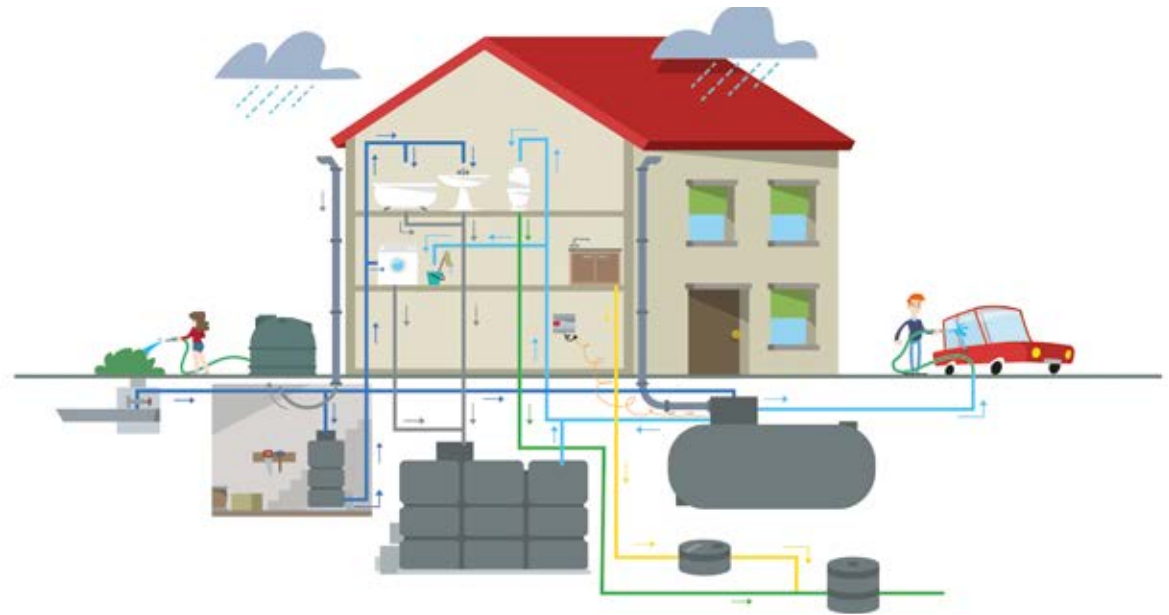

CALYPSO



- panettone
 - dado
 - quadrata
 - valigia
 - verticale
 - cisterna
 - jolly
- anfora
 - orcio

TANKS



- available from 1.000 to 48.000 litres
- available from 24.000 to 200.000 litres

WATER RECOVERY



- bioblu
- biogrigio

AUTOCLAVES



- aut Q with submersible pump
- aut Q with external pump
- aut VA valigia
- aut J jolly

OVERGROUND TANKS CLY



WHERE TO USE IT



FUNCTION AND USE

The tank can be used for the storage of: rainwater, first rain, fire-fighting storage tanks, domestic waste water, landfill leachate, drinking water, etc.

The tank can be drilled on the flat sides for inserting pipes or fittings. It is equipped with a vent on the closing cap and connections for loading, unloading and total emptying. The connections to the tank must be made using flexible joints in order not to stress the connection section.

Female threaded closure cap for preventing material infiltration inside the tank.

IN RESPECT OF REQUIREMENTS

In respect of requirements

EU regulation 213/218

Suitability to contact with food:

Test report IIP n. 821LP/2021 20/10/2021 (blue)

INSTALLATION SCHEME

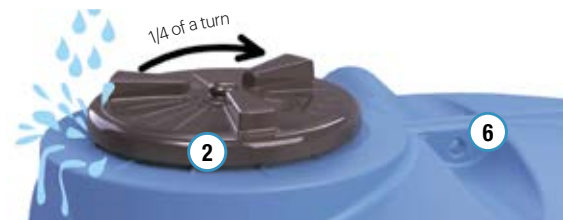
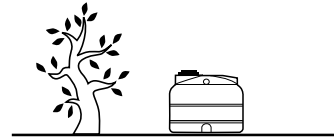

KEY

- ① Storage tank for drinking water or liquids in general
- ② Female bayonet cap for preventing rainwater infiltration
- ③ Vent
- ④ Nr. 3 o-rings for connection to brass inserts 1"
- ⑤ Nr. 3 brass inserts 1"
- ⑥ Lifting eyebolt

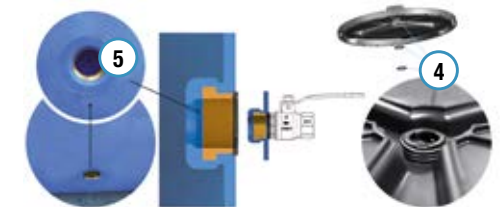

TANKS COLOURS

All the overground tanks are also available, upon request, in the following colours



green



terracotta











grey

TECHNICAL TABLE - PRICE LIST









icon	model	total volume liters	Le x W x h cm	caps Ø cm		vents n.	€
				40	60		

PANETTONE P...

	CLY 3000 P 180	3.000	Ø 180 x 146	1	-	1	765,00
	CLY 4000 P 180	4.000	Ø 180 x 186	1	-	1	1.200,00
	CLY 5000 P 180	5.000	Ø 180 x 226	1	-	1	1.530,00
	CLY 5000 P 220	5.000	Ø 220 x 163	1	-	1	1.530,00
	CLY 7000 P 220	7.000	Ø 220 x 216	1	-	1	2.010,00
	CLY 8000 P 240	8.000	Ø 245 x 201	-	1	1	2.603,00
	CLY 10000 P 240	10.000	Ø 245 x 229	-	1	1	4.095,00
	CLY 15000 P 240	15.000	Ø 245 x 367	-	1	1	5.985,00*

*realized with two electro-welded modules, transport excluded

VERTICALE V...





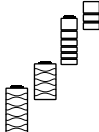

	CLY 150 V 060	150	Ø 60 x 60	1	-	1	190,00
	CLY 300 V 080	300	Ø 80 x 71	1	-	1	220,00
	CLY 400 V 080	400	Ø 80 x 94	1	-	1	250,00
	CLY 500 V 080	500	Ø 80 x 116	1	-	1	290,00
	CLY 800 V 090	800	Ø 90 x 152	1	-	1	390,00
	CLY 1000 V 090	1.000	Ø 90 x 185	1	-	1	450,00
	CLY 1000 V 120	1.000	Ø 120 x 108	1	-	1	450,00
	CLY 1500 V 120	1.500	Ø 120 x 154	1	-	1	595,00
	CLY 2000 V 120	2.000	Ø 120 x 200	1	-	1	685,00

QUADRATA Q...

	CLY 500 Q 070	500	67 x 67 x 124	1	-	1	405,00
	CLY 800 Q 070	800	67 x 67 x 199	1	-	1	555,00
	CLY 1000 Q 090	1.000	95 x 95 x 147	1	-	1	698,00
	CLY 1500 Q 090	1.500	95 x 95 x 200	1	-	1	915,00

icon	model	total volume liters	Le x W x h cm	caps Ø cm		vents n.	€
				30	40		

CISTERNA CT...

	CLY 500 CT 071	500	136 x 71 x 79	1	-	1	295,00
	CLY 1000 CT 090	1.000	170 x 90 x 98	1	-	1	435,00
	CLY 1500 CT 115	1.500	170 x 115 x 126	1	-	1	610,00
	CLY 2000 CT 130	2.000	170 x 130 x 138	1	-	1	795,00
	CLY 3000 CT 145	3.000	200 x 145 x 153	-	1	1	1.090,00
	CLY 5000 CT 170	5.000	247 x 170 x 178	-	1	1	1.845,00

DADO D...

	CLY 300 D 070	250	67 x 67 x 60	1	-	1	300,00
---	---------------	-----	--------------	---	---	---	--------

VALIGIA VA...

	CLY 500 VA 65	500	99 x 65 x 105	1	-	1	430,00
--	---------------	-----	---------------	---	---	---	--------

JOLLY J...

	CLY 1000 J 66	965	145 x 60 x 150	1	-	1	610,00
---	---------------	-----	----------------	---	---	---	--------

OVERGROUND TANKS GARDEN

NEW

WHERE TO USE IT



INSTALLATION SCHEME

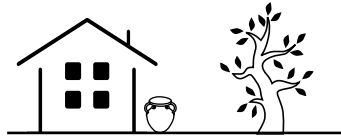

FUNCTION AND USE

The tanks model "orcio" and "anfora" can be used for the collection and storage of rainwater from roofs of buildings. Their design is specially made so that they can be easily inserted for ornamental purposes in both residential and public green areas. They are equipped with loading and unloading connections. The connections to the tank must be realized using flexible joints in order not to stress the connection section. The upper part of the tank is removable and on it it is possible to insert a stainless steel leaf grid on which it is possible to place a vase of flowers or other ornamental object. Ø 200 male threaded closure cap with vent.

STANDARDS AND CERTIFICATIONS

In respect of requirements

EU regulation 213/218

Suitability to contact with water:

Test report IIP n. 0466LP/2022 30/06/2022



KEY

- ① Rainwater storage tank
- ② Leaf grid
- ③ Upper closure lid
- ④ Bayonet closure cap



TECHNICAL TABLE - PRICE LIST

icon	model	total volume liters	Le x W x h cm	caps Ø cm	€
				20	
				n.	

GARDEN





CLY 500 GR 095	500	Ø 95 x 126	1	450,00
-----------------------	------------	------------	---	---------------



CLY 1000 GR 120	1000	Ø 120 x 130	1	680,00
------------------------	-------------	-------------	---	---------------

ACCESSORIES

icon	model	description	material	dimension	€
	GRA Y 300 PF	leaf grid	INOX	Ø 300	80,00
	TTP X 670 GR	tank closure lid	PE	Ø 670	85,00
	FIF X 080 GR	garden leaf filter	PE	Ø 80	140,00

UNDERGROUND TANKS SEI

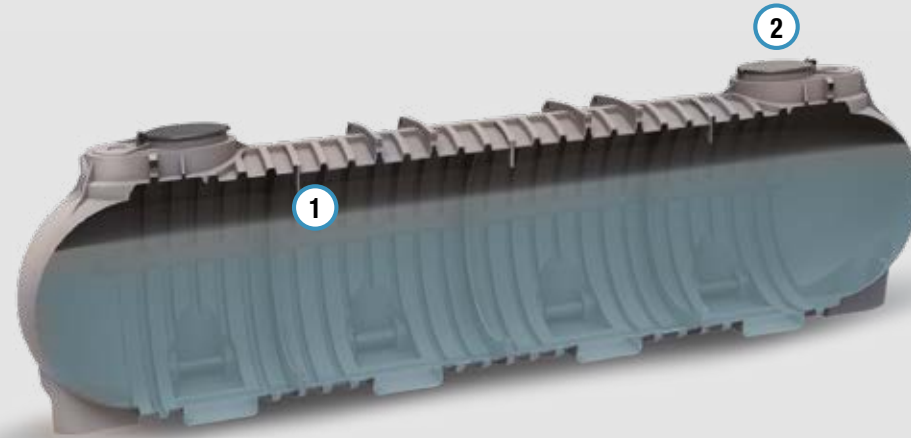

WHERE TO USE IT



INSTALLATION SCHEME

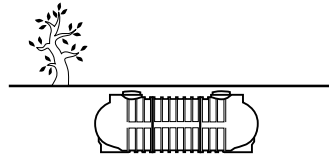

KEY

- ① Storage tank
- ② Flap cap
- ③ Bayonet cap
- ④ Vent

FUNCTION AND USE

The tank can be used for the storage of: rainwater, first rain, fire-fighting storage tanks, domestic waste water, landfill leachate, drinking water, etc.
The tanks can be drilled on the flat sides for inserting pipes or fittings.

STANDARDS AND CERTIFICATIONS

In respect of requirements

EU regulation 213/218





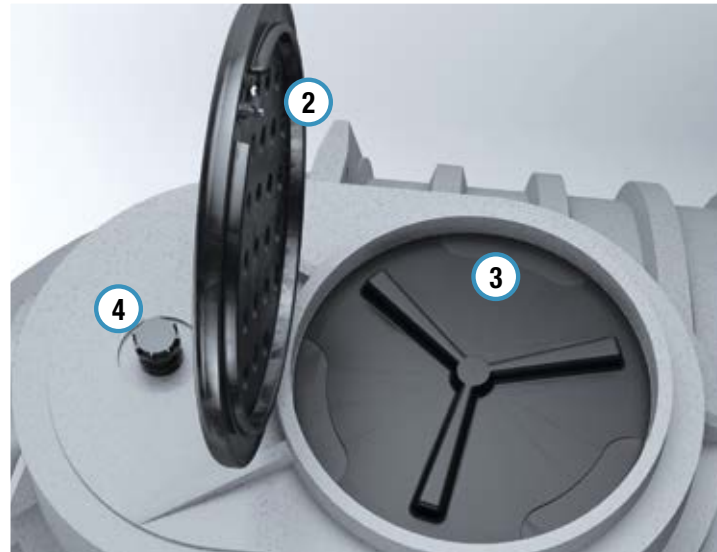



Suitability to contact with food:

Test report IIP n. 823LP/2021 20/10/2021









TECHNICAL TABLE - PRICE LIST







SEI CC...

icon	model	total volume liters	Le x W x h cm	caps Ø cm		€
				40	60	
				n.		
	 SEI CC 1000 AG	1.050	Ø 130 x 103	1	-	660,00
	 SEI CC 1200 AG	1.400	Ø 130 x 133	1	-	810,00
	 SEI CC 1800 AG	1.900	Ø 130 x 178	1	-	1.020,00
	 SEI CC 2000 AG	2.150	Ø 130 x 200	1	-	1.170,00
	 SEI CC 2100 AG	2.450	Ø 150 x 167	1	-	1.470,00
	 SEI CC 2600 AG	2.800	Ø 150 x 182	1	-	1.650,00
	 SEI CC 3000 AG	3.300	Ø 165 x 177	1	-	2.025,00
	 SEI CC 3500 AG	3.700	Ø 165 x 200	1	-	2.100,00





SEI N...

	 SEI N 2000 AG	2.020	210 x 125 x 134	-	1	1.425,00
	 SEI N 3000 AG	2.930	290 x 125 x 134	-	1	2.025,00
	 SEI N 5000 AG	5.000	240 x 180 x 187	-	1	2.475,00
	 SEI N 6000 AG	5.870	238 x 186 x 195	-	1	2.850,00
	 SEI N 9000 AG	8.650	285 x 210 x 234	-	1	5.250,00















SEI MP...

	 SEI MP 3700 AG	3.700	371 x 125 x 134	-	1	2.970,00
	 SEI MP 5000 AG	4.600	451 x 125 x 134	-	2	3.600,00
	 SEI MP 5500 AG	5.600	531 x 125 x 134	-	2	4.350,00
	 SEI MP 7000 AG	6.600	632 x 125 x 134	-	2	5.100,00
	 SEI MP 9000 AG	8.600	813 x 125 x 134	-	2	6.600,00

SEI MM...

icon	model	total volume liters	Le x W x h cm	caps Ø cm		€
				60		
				n.		
	 SEI MM 7500 AG	7.200	355 x 176 x 186	2		5.400,00
	 SEI MM 8500 AG	8.500	415 x 176 x 186	2		6.300,00
	 SEI MM 10000 AG	10.000	445 x 176 x 186	2		6.600,00
	 SEI MM 11000 AG	11.600	535 x 176 x 186	2		8.850,00

SEI M... / MN...

	 SEI M 12000 AG	12.750	440 x 210 x 234	2		8.100,00
	 SEI MN 15000 AG	14.880	465 x 210 x 234	2		10.200,00
	 SEI M 18000 AG	18.980	620 x 210 x 234	2		12.900,00
	 SEI MN 21000 AG	21.110	645 x 210 x 234	2		14.400,00
	 SEI M 24000 AG	25.200	800 x 210 x 234	2		16.350,00
	 SEI MN 27000 AG	27.340	825 x 210 x 234	2		18.750,00
	 SEI M 30000 AG	31.420	980 x 210 x 234	2		20.250,00
	 SEI MN 33000 AG	33.580	1005 x 210 x 234	2		23.700,00
	 SEI M 36000 AG	37.650	1160 x 210 x 234	2		25.200,00
	 SEI MN 39000 AG	40.100	1185 x 210 x 234	2		28.650,00
	 SEI M 42000 AG	43.870	1340 x 210 x 234	2		31.800,00
	 SEI M 48000 AG	50.100	1520 x 210 x 234	2		35.850,00*

* Welding on site not included in the price.

CONTINUOUS MODULAR UNDERGROUND TANKS SEI MC



FUNCTION AND USE

The tank can be used for the storage of: rainwater, first rain, fire-fighting storage tanks, domestic waste water, landfill leachate, drinking water, lamination plants, etc. Tanks must be installed on a flat uniform horizontal surface, which must be equal or bigger than the base of the tank.

The tanks can be drilled on the flat sides for inserting pipes or fittings.

STANDARDS AND CERTIFICATIONS

In respect of requirements

EU regulation 213/218

Suitability to contact with food:

Test report IIP n. 823LP/2021 20/10/2021

COMPONENTS



TERMINAL WITH
INSPECTION TURRET



CENTRAL



CENTRAL
WITH TURRET



BENT 45°



BENT 45°
WITH TURRET

ADVANTAGES

*Large volumes
in contained spaces*

*Full bore
internal surface*

*Possibility of installing
customized inspection holes*

*Mechanical seal through
bolting of modules*

*Horizontal and vertical
reinforcement ribs*



TECHNICAL TABLE - PRICE LIST

SEI MCO (N.2 WELDINGS*)



icon	model	total volume liters	Le x W x h cm	caps Ø cm	€
				60 n.	
	SEI MCO 24000	24.000	462 x 462 x 232	2	20.250,00*
	SEI MCO 36000	36.000	641 x 461 x 232	4	28.350,00*
	SEI MCO 48000	48.000	821 x 461 x 232	4	36.150,00*
	SEI MCO 60000	60.000	1001 x 461 x 232	4	41.700,00*
	SEI MCO 72000	72.000	1181 x 461 x 232	6	50.850,00*
	SEI MCO 84000	84.000	1361 x 461 x 232	7	58.950,00*

SEI MCU (N.1 WELDING*)



	SEI MCU 36000	36.000	630 x 462 x 232	4	25.350,00*
	SEI MCU 48000	48.000	810 x 461 x 232	5	33.450,00*
	SEI MCU 60000	60.000	990 x 461 x 232	5	41.700,00*
	SEI MCU 72000	72.000	1.170 x 461 x 232	7	49.500,00*
	SEI MCU 84000	84.000	1.350 x 461 x 232	8	58.350,00*

SEI MCC (N.5 WELDINGS*)



	SEI MCC 114000	114.000	1.000 x 1.001 x 232	5	73.800,00*
	SEI MCC 126000	126.000	1.180 x 1.001 x 232	9	93.450,00*
	SEI MCC 162000	162.000	1.360 x 1.001 x 232	9	114.000,00*
	SEI MCC 186000	186.000	1.540 x 1.010 x 232	9	123.300,00*

* Welding on site excluded

NB For this type of tank it is necessary to complete the assembly on site.

In addition to the configuration proposed in this catalogue, it is possible to customize volumes and lay-out according to the customer's needs.

WATER RECOVERY | BIOBLU

RAINWATER REUSE PLANT BIOBLU



KEY

- A** Rain water storage tank
- B** Leaf filter, overflow and decanter pipe
- C** Service tank with one-way valve
- D** Pressurization pump
- E** Control unit IIRI / IDRO
- F** Control unit protection box

WHERE TO USE IT



INSTALLATION SCHEME

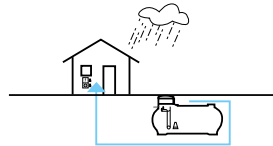

FUNCTION AND USE

BIOBLU plant allows rainwater collection to be later reused for both individual and public needs. It consists of a storage tank and a control unit for the booster pump. Such water can be reused for toilet flushing, irrigation and washing vehicles. It is however mandatory to keep drinking water used for self-hygiene, body care and cooking always connected to the public aqueduct network.

STANDARDS AND CALCULATION PARAMETERS















EN 11445:2012



COMPONENTS KEY

	BASE	IIRI	IDRO
Tank	x	x	x
Service turret	x	x	x
Manhole inspection	x	x	x
Cap Ø 620 bayonet closure	x	x	x
Cap Ø 750 flip closure	x	x	x
Flip cap key closure	x	x	x
Vent	x	x	x
Pipe inlet PE Ø 125	x	x	x
Leaf filter outlet and overflow pipe PE Ø 125	x	x	x
Self-cleaning leaf filter	x	x	x
Leaf filter inspection key closure	x	x	x
Decanter pipe	x	x	x
Submersible pump	-	x	x
Floating switch for minimum water level	-	x	x
Pipe PE Ø 32 pump delivery	-	x	x
Service tank litres 30	-	x	x
Switches for min/max water level	-	-	x
One-way valve	-	-	x
Pipe PE Ø 20 for mains water replenishment	-	-	x
External control unit IIRI	-	x	-
External control unit IDRO	-	-	x

TECHNICAL TABLE - PRICE LIST

icon	model	total volume liters	Le x W x h cm	overflow he / hu cm	Ø in/out mm	caps Ø cm	leaf filter type	submersible pump Q 5÷90 lt/min - h 5,8÷0,8 m - pot. 1,2 kW			external control box			€		
						60		BA	IR	ID	BA	IR*	ID**	BA (base)	IR (irrigation)	ID (hydraulic)
						n.										
	IAP N 2000 ..	2.020	210 x 125 x 133	113 / 111	125	1	internal	-	1	1	-	1	1	1.925,00	3.955,00	6.225,00
	IAP N 3000 ..	2.930	290 x 125 x 133	113 / 111	125	1	internal	-	1	1	-	1	1	2.540,00	4.570,00	6.840,00
	IAP N 5000 ..	5.000	245 x 175 x 199	166 / 164	125	1	internal	-	1	1	-	1	1	3.175,00	5.205,00	7.475,00
	IAP N 6000 ..	5.870	238 x 186 x 233	205 / 203	125	1	internal	-	1	1	-	1	1	3.570,00	5.600,00	7.870,00
	IAP N 9000 ..	8.650	285 x 210 x 266	238 / 236	125	1	internal	-	1	1	-	1	1	5.950,00	7.980,00	10.245,00
	IAP MP 5000 ..	4.600	451 x 125 x 133	113 / 111	125	2	internal	-	1	1	-	1	1	4.280,00	6.310,00	8.580,00
	IAP MP 7000 ..	6.600	632 x 125 x 133	113 / 111	125	2	internal	-	1	1	-	1	1	5.860,00	7.895,00	10.160,00
	IAP MP 9000 ..	8.600	813 x 125 x 133	113 / 111	125	2	internal	-	1	1	-	1	1	7.455,00	9.485,00	11.750,00
	IAP MM 7500 ..	7.200	355 x 176 x 221	192 / 190	125	2	internal	-	1	1	-	1	1	6.335,00	8.365,00	10.635,00
	IAP MM 8500 ..	8.500	415 x 176 x 221	192 / 190	125	2	internal	-	1	1	-	1	1	7.245,00	9.280,00	11.550,00
	IAP MM 10000 ..	10.000	445 x 176 x 221	192 / 190	125	2	internal	-	1	1	-	1	1	7.470,00	9.500,00	11.770,00
	IAP M 12000 ..	12.750	440 x 210 x 266	238 / 236	125	2	internal	-	1	1	-	1	1	8.870,00	10.900,00	13.170,00
	IAP MN 15000 ..	14.880	465 x 210 x 266	238 / 236	125	2	internal	-	1	1	-	1	1	10.935,00	12.965,00	15.235,00
	IAP M 18000 ..	18.980	620 x 210 x 266	238 / 236	125	2	internal	-	1	1	-	1	1	13.770,00	15.800,00	18.070,00
	IAP MN 21000 ..	21.100	645 x 210 x 266	238 / 236	125	2	internal	-	1	1	-	1	1	15.185,00	17.220,00	19.485,00

CONTROL UNITS EQUIPMENT

*External control unit IR:

- Pressure switch 1,4÷4,6 bar
- Expansion tank 8 litres
- Control panel 230 Volt
- Connections 1"

**External control unit ID:

- Pressure switch 1,4÷4,6 bar
- Expansion tank 8 litres
- Control panel 230 Volt
- Pump inlet 1"
- Mains water inlet 3/4"
- Cartridge filter 120 micron
- Proportional chlorine dispenser 0,10 litres

WATER RECOVERY | BIOGRIGIO

GREY WATER REUSE PLANT BIOGRIGIO



WHERE TO USE IT



INSTALLATION SCHEME

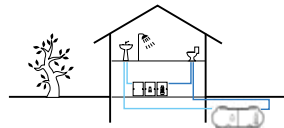

KEY

- (A)** Primary sedimentation
- (B)** Biological oxidation
- (C)** Equalization pump
- (D)** Ultrafiltration
- (E)** Permeate removal

FUNCTION AND USE

BIOGRIGIO plant allows the recovery and reuse of grey waters for irrigation and domestic purposes.

Grey water refers to water coming from sinks, showers and bathtubs (excluding kitchen sinks).



They are collected and treated to be sent to households which do not require drinking water. They are generally used for large numbers of users such as in hotels, schools, condominiums, etc.

Downstream of the plant it is necessary to install a suitable storage tank for the purified water used for the permitted purposes (flushing toilet, irrigation, washing vehicles, etc.). It is however mandatory to keep drinking water used for self-hygiene, body care and cooking always connected to the public aqueduct network.





TECHNICAL TABLE - PRICE LIST

BGR I UNDERGROUND

icon	model	potential population	Le x W x h cm	overflow he / hu cm	Ø in/out mm	caps Ø cm		€
						40	60 n.	
	BGR 10÷30 I 1000	10÷30	371 x 125 x 134	118 / 115	80	-	2	13.390,00
	BGR 30÷50 I 2000	30÷50	371 x 125 x 134	118 / 115	80	-	2	15.280,00
	BGR 50÷70 I 3000	50÷70	490 x 130 x 178	108 / 151	80	2	1	18.900,00

BGR E OVERGROUND

icon	model	potential population	Le x W x h cm	overflow he / hu cm	Ø in/out mm	caps Ø cm		€
						40	60 n.	
	BGR 10÷30 E 1000	10÷30	219 x 81 x 128	128 / 128	80	2	1	15.435,00
	BGR 30÷50 E 2000	30÷50	290 x 81 x 128	128 / 128	80	3	1	17.640,00
	BGR 50÷70 E 3000	50÷70	490 x 130 x 151	108 / 151	80	2	1	18.900,00

WATER RECOVERY | AUTOCLAVES

AUT AUTOCLAVES

AUT Q EST*
WITH
EXTERNAL
PUMP



AUT Q IN*
WITH
SUBMERSIBLE
PUMP



AUT VA
VALIGIA



AUT J
JOLLY



WHERE TO USE IT



INSTALLATION SCHEME

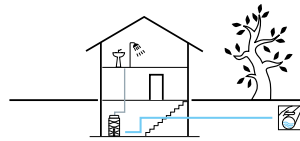

FUNCTION AND USE

Autoclaves are suitable for the pressurization of small households in order to maintain the network pressure and as a water reserve in case of temporary closure of the supply service of drinking water. Completely automated, it consists of a polyethylene tank with housing compartment for external pump or pressure switch when using a submersible pump and protective cover.

The tank is equipped with an inlet with a float valve for replenishing the water from the aqueduct.

STANDARDS AND CERTIFICATIONS

In respect of requirements

*EN 1717:2022

EU regulation 213/218

Suitability to contact with food:

Test report IIP n. 821LP/2021 20/10/2021 (blue)

Suitability to contact with water:

Test report IIP n. 0464LP/2022 - 30/10/2022 (grey)



COMPONENTS KEY

	Q EST	Q IN	VA	J
Tank	X	X	X	X
Cap with vent	X	X	X	X
Load valve	X	X	X	X
Overflow	X	X	X	X
Pressurization pump	X	X	X	X
Pumps lifting chain	-	X	X	X
Suction pipe	X	X	X	X
Delivery pipes	X	X	X	X
Suction fittings	X	-	-	-
Foot valve	X	-	-	-
Delivery fittings	X	X	X	X
Flow pressure switch	-	X	-	-
Anchoring plate	X	-	-	-
Protection hood	X	X	-	-

TECHNICAL TABLE - PRICE LIST

EXTERNAL PUMP



model	volume liters	dimensional characteristics					TOP configuration				€	accessories	
		Le x W x h		pumps			tank	pump	mechanical components	pipes		hood	packaging
		mm		mod.	kW	Ø						€	
AUT Q 500 EST 055 CM	500	67 x 67 x 149	POM Z P 055 CME	0,55	1"	570,00	675,00	160,00	55,00	1.460,00	95,00	45,00	
AUT Q 500 EST 075 CM	500	67 x 67 x 149	POM Z P 075 CME	0,75	1"	570,00	715,00	160,00	55,00	1.500,00	95,00	45,00	

SUBMERSIBLE PUMP



model	volume liters	dimensional characteristics					TOP configuration				€	accessories	
		Le x W x h		pumps			tank	pump	mechanical components	pressure switch		hood	packaging
		mm		mod.	kW	Ø						€	
AUT Q 500 IN 055 CM	500	67 x 67 x 149	POM Z P 055 CMI	0,55	1"	510,00	860,00	65,00	195,00	1.630,00	95,00	45,00	
AUT Q 500 IN 080 CM	500	67 x 67 x 149	POM Z P 075 CMI	0,75	1"	510,00	880,00	65,00	195,00	1.650,00	95,00	45,00	

VALIGIA



model	volume liters	dimensional characteristics					TOP configuration			€
		Le x W x h		pumps			tank	pump	pipes	
		mm		mod.	kW	Ø				
AUT VA 500 IN 255 PM	500	99 x 65 x 105	POM Z P 255 PMI	0,55	1"	450,00	690,00	145,00	1.285,00	
AUT VA 500 IN 355 PM	500	99 x 65 x 105	POM Z P 355 PMI	0,55	1"	450,00	710,00	145,00	1.305,00	

JOLLY



model	volume liters	dimensional characteristics					TOP configuration			€
		Le x W x h		pumps			tank	pump	pipes	
		mm		mod.	kW	Ø				
AUT J 1000 IN 255 PM	1.000	145 x 60 x 150	POM Z P 255 PMI	0,55	1"	625,00	690,00	145,00	1.460,00	
AUT J 1000 IN 355 PM	1.000	145 x 60 x 150	POM Z P 355 PMI	0,55	1"	625,00	710,00	145,00	1.480,00	



HYDRAULICS

As part of the research for increasingly high-performance and easy-to use plant solutions, in compliance with national and European standards, DI CAMILLO SERBATOI also manufactures specific products for some sectors of hydraulic plant engineering.

Among these, the solutions relative to water lifting systems and fire-fighting systems are particularly successful and cost-effective.

LIFTING STATIONS

The increasing use of often underground works inevitably implies the necessity to use a lifting system with the function of bringing water to a higher level with the aid of pumps.

FIRE-FIGHTING

Offire

The plant complies with the required standards and it is complete with water reserve and pressurization station. It is totally underground, without technical rooms but equipped with a simple external control panel.

Fire-fighting water storage tank

Tanks used for above ground pressurization stations complete with all the accessories required for hydraulic connections.



LIFTING STATIONS



- babysol small
- babysol
- minisol
- minisol XL
- maxisol
- maxisol XL
- corrugated

FIRE-FIGHTING SYSTEM



- offire

FIRE-FIGHTING STORAGE



- tank equipped for overground plants

BABYSOL SMALL BSS



WHERE TO USE IT



Lifting Station Babysol is generally used downstream of small domestic discharges.

INSTALLATION SCHEME

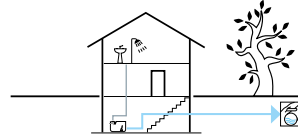

KEY

- ① Tank
- ② Tank/pump inspection: cap Ø 400 bayonet closure
- ③ Pipe/basket inlet inspection: threaded cap Ø 113
- ④ Sewage inlet pipe
- ⑤ Large mesh basket in PE
- ⑥ Pump delivery pipes
- ⑦ Submersible pump
- ⑧ Cast iron ball check valve
- ⑨ Float switches integrated in the pump

FUNCTION AND USE

Lifting station BABYSOL SMALL consists of a polyethylene tank, with the function of collecting and bringing rainwater or wastewater to a higher level. Inside there is a pumping system controlled by floats and electric panel. The system is suitable for lifting small size units and must be installed in basements etc.

The screening basket positioned at the inlet is designed for holding coarse solids that would clog the pumps (lumps of paper, plastic materials, paper cloth, etc.).

If the quantity of solids is substantial, the use of pre-treatments upstream of the station is recommended.

TECHNICAL TABLE - PRICE LIST

COMPLETE TOP CONFIGURATION PRICE LIST

model	dimensional characteristics							TOP configuration set-up			total €	optional				
	volume liters	Le	x	W	x	h	pumps		tank	delivery pipes €		pump	check valve	panel	fixing plate	
							n.	power KW								delivery Ø"
BSS 100 L037MM	100	76	x	50	x	59	1	0,37	1"1/4	232,00	76,00	415,00	723,00	143,00	290,00	298,00
BSS 100 L060MM		76	x	50	x	59	1	0,6	1"1/4	232,00	76,00	575,00	883,00	143,00	290,00	298,00
BSS 100 L075MM		76	x	50	x	59	1	0,75	1"1/2	232,00	91,00	615,00	938,00	146,00	290,00	298,00
BSS 100 L037ZM		76	x	50	x	59	1	0,37	1"1/2	232,00	91,00	560,00	883,00	146,00	290,00	298,00
BSS 100 L060AM		76	x	50	x	59	1	0,6	1"1/2	232,00	91,00	535,00	858,00	146,00	290,00	298,00
BSS 100 T075PM		76	x	50	x	59	1	0,75	1"1/4	232,00	76,00	1.480,00	1.788,00	143,00	290,00	298,00
BSS 100 T090AM		76	x	50	x	59	1	0,9	1"1/4	232,00	76,00	1.465,00	1.773,00	143,00	290,00	298,00
BSS 100 T110AM		76	x	50	x	59	1	1,1	1"1/4	232,00	76,00	1.520,00	1.828,00	143,00	290,00	298,00
BSS 200 L037MM	200	76	x	50	x	85	1	0,37	1"1/4	262,00	76,00	415,00	753,00	143,00	290,00	298,00
BSS 200 L060MM		76	x	50	x	85	1	0,6	1"1/4	262,00	76,00	575,00	913,00	143,00	290,00	298,00
BSS 200 L075MM		76	x	50	x	85	1	0,75	1"1/2	262,00	91,00	615,00	968,00	146,00	290,00	298,00
BSS 200 L037ZM		76	x	50	x	85	1	0,37	1"1/2	262,00	91,00	560,00	913,00	146,00	290,00	298,00
BSS 200 L060AM		76	x	50	x	85	1	0,6	1"1/2	262,00	91,00	535,00	888,00	146,00	290,00	298,00
BSS 200 T090AM		76	x	50	x	85	1	0,9	1"1/4	262,00	76,00	1.465,00	1.803,00	143,00	290,00	298,00
BSS 200 T075PM		76	x	50	x	85	1	0,75	1"1/4	262,00	76,00	1.480,00	1.818,00	143,00	290,00	298,00
BSS 200 T110AM		76	x	50	x	85	1	1,1	1"1/4	262,00	76,00	1.520,00	1.858,00	143,00	290,00	298,00

Notes: in case of float integrated with the pump, electric panel is not required.

In case the pump does not come with integrated float, it is necessary to install the electric panel and nr. 2 float switches (cod. INT GAL G) price €/cad. 125,00.

BABYSOL BBS



WHERE TO USE IT



Lifting Station Babysol is generally used downstream of small domestic discharges.

INSTALLATION SCHEME

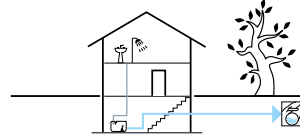

KEY

- ① Tank
- ② Tank/pump inspection: cap Ø 350 with threaded closure
- ③ Pipe/basket inlet inspection: cap Ø 140 bayonet closure
- ④ Sewage inlet
- ⑤ Large mesh basket in PE for coarse bodies removal
- ⑥ Pump delivery pipes
- ⑦ Float switches:
 - single-pump version float integrated with the pump
 - double-pump version n. 3 floats (those integrated with pump blocked)
- ⑧ Submersible pump
- ⑨ Cast iron ball check valve

FUNCTION AND USE

Lifting station BABYSOL consists of a polyethylene tank, with the function of collecting and bringing rainwater or wastewater to a higher level. Inside there is a pumping system controlled by floats and electric panel. The system is suitable for lifting small size units and must be installed in basements etc.

The screening basket positioned at the inlet is designed for holding coarse solids that would clog the pumps (lumps of paper, plastic materials, paper cloth, etc.).

If the quantity of solids is substantial, the use of pre-treatments upstream of the station is recommended.

TECHNICAL TABLE - PRICE LIST

COMPLETE TOP CONFIGURATION PRICE LIST

model	dimensional characteristics					TOP configuration set-up			total	optional	
	volume	Le x W x h	n.	pumps		tank	delivery pipes	pump		check valve	electric panel
				power	delivery						
liters	cm		KW	"							
BBS TOP 101 L037MM	100	80 x 50 x 56	1*	0,37	1"1/4	451,00	67,00	415,00	933,00	143,00	290,00
BBS TOP 101 L060MM		80 x 50 x 56	1*	0,6	1"1/4	451,00	67,00	575,00	1.093,00	143,00	290,00
BBS TOP 101 L075MM		80 x 50 x 56	1*	0,75	1"1/2	451,00	83,00	615,00	1.149,00	146,00	290,00
BBS TOP 101 T075PM		80 x 50 x 56	1*	0,75	1"1/4	451,00	67,00	1.480,00	1.998,00	143,00	290,00
BBS TOP 101 T110AM		80 x 50 x 56	1*	1,1	1"1/4	451,00	67,00	1.520,00	2.038,00	143,00	290,00
BBS TOP 102 L037MM	200	80 x 100 x 56	2	0,37	1"1/4	831,00	424,00	830,00	2.085,00	286,00	335,00
BBS TOP 102 L060MM		80 x 100 x 56	2	0,6	1"1/4	831,00	424,00	1.150,00	2.405,00	286,00	335,00
BBS TOP 102 L075MM		80 x 100 x 56	2	0,75	1"1/2	831,00	461,00	1.230,00	2.522,00	292,00	335,00
BBS TOP 102 T075PM		80 x 100 x 56	2	0,75	1"1/4	831,00	424,00	2.960,00	4.215,00	286,00	335,00
BBS TOP 102 T110AM		80 x 100 x 56	2	1,1	1"1/4	831,00	424,00	3.040,00	4.295,00	286,00	335,00
BBS TOP 201 L037MM	200	80 x 50 x 84	1*	0,37	1"1/4	702,00	67,00	415,00	1.184,00	143,00	290,00
BBS TOP 201 L060MM		80 x 50 x 84	1*	0,6	1"1/4	702,00	67,00	575,00	1.344,00	143,00	290,00
BBS TOP 201 L075MM		80 x 50 x 84	1*	0,75	1"1/2	702,00	83,00	615,00	1.400,00	146,00	290,00
BBS TOP 201 L110MM		80 x 50 x 84	1*	1,1	2"	702,00	123,00	965,00	1.790,00	146,00	290,00
BBS TOP 201 T110AM		80 x 50 x 84	1*	1,1	1"1/4	702,00	67,00	1.520,00	2.289,00	143,00	290,00
BBS TOP 201 T150PM		80 x 50 x 84	1*	1,5	1"1/4	702,00	67,00	2.560,00	3.329,00	143,00	290,00
BBS TOP 202 L037MM	400	80 x 100 x 84	2	0,37	1"1/4	1.414,00	424,00	830,00	2.668,00	286,00	335,00
BBS TOP 202 L060MM		80 x 100 x 84	2	0,6	1"1/4	1.414,00	424,00	1.150,00	2.988,00	286,00	335,00
BBS TOP 202 L075MM		80 x 100 x 84	2	0,75	1"1/2	1.414,00	461,00	1.230,00	3.105,00	292,00	335,00
BBS TOP 202 L110MM		80 x 100 x 84	2	1,1	2"	1.414,00	540,00	1.930,00	3.884,00	292,00	335,00
BBS TOP 202 T110AM		80 x 100 x 84	2	1,1	1"1/4	1.414,00	424,00	3.040,00	4.878,00	286,00	335,00
BBS TOP 202 T150PM		80 x 100 x 84	2	1,5	1"1/4	1.414,00	424,00	5.120,00	6.958,00	286,00	335,00

* Model n.1 pump: float integrated with the pump (electric panel not required).

MINISOL MNS



WHERE TO USE IT



Lifting Station Minisol is generally used downstream of small domestic discharges.

INSTALLATION SCHEME

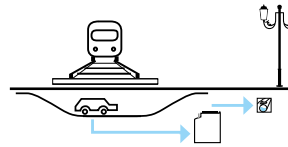

KEY

- ① Tank
- ② Tank/pump inspection: cap Ø 600 bayonet closure
- ③ Sewage inlet pipe
- ④ Pump delivery pipes
- ⑤ Float switches:
 - single-pump version float integrated with the pump
 - double-pump version n. 3 floats (those integrated with pump blocked)
- ⑥ Submersible pump
- ⑦ Cast iron ball check valve

FUNCTION AND USE

Lifting station MINISOL consists of a vertical cylindrical polyethylene tank, with the function of collecting and bringing rainwater or wastewater to a higher level.

Inside there is a pumping system controlled by floats and electric panel.

The system is suitable for lifting small and medium size units with maximum delivery diameters DN 50.

The use of pre-treatments upstream of the station is recommended.

TECHNICAL TABLE - PRICE LIST

COMPLETE TOP CONFIGURATION PRICE LIST

model	dimensional characteristics							TOP configuration set-up			total	optional				
	volume liters	Le	x	W	x	h	pumps		tank	delivery pipes		pump	€	check valve	electric panel	
							n.	power KW			delivery Ø"					€
MNS TOP 251 L037MM	250	78	x	78	x	65	1	0,37	1"1/4	380,00	67,00	415,00	862,00	143,00	290,00	
MNS TOP 252 L037MM		78	x	78	x	65	2			380,00	424,00	830,00	1.634,00	286,00	335,00	
MNS TOP 251 L060MM		78	x	78	x	65	1	0,6	1"1/4	380,00	67,00	575,00	1.022,00	143,00	290,00	
MNS TOP 252 L060MM		78	x	78	x	65	2			380,00	424,00	1.150,00	1.954,00	286,00	335,00	
MNS TOP 251 L075MM		78	x	78	x	65	1	0,75	1"1/2	380,00	83,00	615,00	1.078,00	146,00	290,00	
MNS TOP 252 L075MM		78	x	78	x	65	2			380,00	457,00	1.230,00	2.067,00	292,00	335,00	
MNS TOP 251 T075PM		78	x	78	x	65	1	0,75	1"1/4	380,00	67,00	1.480,00	1.927,00	143,00	290,00	
MNS TOP 252 T075PM		78	x	78	x	65	2			380,00	424,00	2.960,00	3.764,00	286,00	335,00	
MNS TOP 251 T110AM		78	x	78	x	65	1	1,1	1"1/4	380,00	67,00	1.520,00	1.967,00	143,00	290,00	
MNS TOP 252 T110AM		78	x	78	x	65	2			380,00	424,00	3.040,00	3.844,00	286,00	335,00	
MNS TOP 401 L037MM		400	78	x	78	x	95	1	0,37	1"1/4	480,00	67,00	415,00	962,00	143,00	290,00
MNS TOP 402 L037MM			78	x	78	x	95	2			480,00	424,00	830,00	1.734,00	286,00	335,00
MNS TOP 401 L060MM	78		x	78	x	95	1	0,6	1"1/4	480,00	67,00	575,00	1.122,00	143,00	290,00	
MNS TOP 402 L060MM	78		x	78	x	95	2			480,00	424,00	1.150,00	2.054,00	286,00	335,00	
MNS TOP 401 L075MM	78		x	78	x	95	1	0,75	1"1/2	480,00	83,00	615,00	1.178,00	146,00	290,00	
MNS TOP 402 L075MM	78		x	78	x	95	2			480,00	457,00	1.230,00	2.167,00	292,00	335,00	
MNS TOP 401 L110MM	78		x	78	x	95	1	1,1	2"	480,00	123,00	965,00	1.568,00	169,00	290,00	
MNS TOP 402 L110MM	78		x	78	x	95	2			480,00	530,00	1.930,00	2.940,00	338,00	335,00	
MNS TOP 401 T110AM	78		x	78	x	95	1	1,1	1"1/4	480,00	67,00	1.520,00	2.067,00	143,00	290,00	
MNS TOP 402 T110AM	78		x	78	x	95	2			480,00	424,00	3.040,00	3.944,00	286,00	335,00	
MNS TOP 401 T150PM	78		x	78	x	95	1	1,5	1"1/4	480,00	67,00	2.560,00	3.107,00	143,00	290,00	
MNS TOP 402 T150PM	78		x	78	x	95	2			480,00	424,00	5.120,00	6.024,00	286,00	335,00	

MINISOL XL MNX

FREE PUMP



WHERE TO USE IT



Lifting Station Minisol XL is generally used downstream of small domestic discharges.

INSTALLATION SCHEME

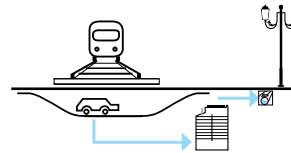

KEY

- ① Tank
- ② Folding lid
- ③ Sewage inlet pipe
- ④ Pump delivery pipes
- ⑤ Pumped liquid outlet pipes
- ⑥ Float switches
- ⑦ Submersible pump
- ⑧ Cast iron ball check valve

FUNCTION AND USE

Lifting station MINISOL XL consists of a vertical cylindrical polyethylene tank, with the function of collecting and bringing rainwater or wastewater to a higher level.

Inside there is a pumping system controlled by floats and electric panel. It can be equipped with a quick coupling system or with free pump. The system is suitable for lifting small and medium size units with maximum delivery diameters DN 50.

The use of pre-treatments upstream of the station is recommended.

TECHNICAL TABLE - PRICE LIST

COMPLETE TOP CONFIGURATION PRICE LIST FREE PUMP

model	dimensional characteristics					TOP configuration set-up			total	optional	
	volume	Le x h	pumps			tank	delivery pipes	pump		check valve	electric panel
			liters	cm	n.						
				KW	"						
MNX TOP 0651 L060MM PL	650	Ø 100 x 120	1	0,60	1"1/4	1.190,00	133,00	575,00	1.898,00	143,00	290,00
MNX TOP 0652 L060MM PL			2			1.190,00	543,00	1.150,00		2.883,00	286,00
MNX TOP 0651 L075AM PL			1	0,75	1"1/2	1.190,00	153,00	590,00	1.933,00	146,00	290,00
MNX TOP 0652 L750AM PL			2			1.190,00	590,00	1.180,00		2.960,00	292,00
MNX TOP 0801 L075MM PL	800	Ø 100 x 140	1	0,75	1"1/2	1.370,00	153,00	615,00	2.138,00	146,00	290,00
MNX TOP 0802 L075MM PL			2			1.370,00	590,00	1.230,00		3.190,00	292,00
MNX TOP 0801 L110AM PL			1	1,10	2"	1.370,00	199,00	930,00	2.499,00	169,00	290,00
MNX TOP 0802 L110AM PL			2			1.370,00	679,00	1.860,00		3.909,00	338,00
MNX TOP 1001 L060AM PL	1000	Ø 100 x 170	1	0,60	1"1/2	1.600,00	153,00	535,00	2.288,00	146,00	290,00
MNX TOP 1002 L060AM PL			2			1.600,00	590,00	1.070,00		3.260,00	292,00
MNX TOP 1001 L110MM PL			1	1,10	2"	1.600,00	199,00	965,00	2.764,00	169,00	290,00
MNX TOP 1002 L110MM PL			2			1.600,00	679,00	1.930,00		4.209,00	338,00
MNX TOP 1201 L037ZM PL	1200	Ø 100 x 200	1	0,37	1"1/2	1.805,00	153,00	560,00	2.518,00	146,00	290,00
MNX TOP 1202 L037ZM PL			2			1.805,00	590,00	1.120,00		3.515,00	292,00
MNX TOP 1201 L110AM PL			1	1,10	2"	1.805,00	199,00	930,00	2.934,00	169,00	290,00
MNX TOP 1202 L110AM PL			2			1.805,00	679,00	1.860,00		4.344,00	338,00
MNX TOP 1451 L120DM PL	1450	Ø 100 x 230	1	1,20	2"	2.010,00	199,00	1.325,00	3.534,00	169,00	290,00
MNX TOP 1452 L120DM PL			2			2.010,00	679,00	2.650,00		5.339,00	338,00

HYDRAULICS | LIFTING STATIONS

MINISOL XL MNX

PUMP AND
COUPLING FOOT



WHERE TO USE IT



FUNCTION AND USE

Lifting station MINISOL XL consists of a vertical cylindrical polyethylene tank, with the function of collecting and bringing rainwater or wastewater to a higher level.

Inside there is a pumping system controlled by floats and electric panel. It can be equipped with a quick coupling system or with free pump. The system is suitable for lifting small and medium size units with maximum delivery diameters DN 50.

The use of pre-treatments upstream of the station is recommended.

INSTALLATION SCHEME

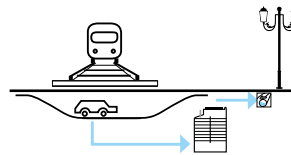

KEY

- ① Tank
- ② Folding lid
- ③ Sewage inlet pipe
- ④ Base in PE for coupling foot fixing
- ⑤ Quick coupling foot
- ⑥ Pump guide pipes
- ⑦ Pump delivery pipes
- ⑧ Pumped liquid outlet pipes
- ⑨ Float switches
- ⑩ Submersible pump
- ⑪ Cast iron ball check valve

TECHNICAL TABLE - PRICE LIST

COMPLETE TOP CONFIGURATION PRICE LIST PUMP AND COUPLING FOOT

model	dimensional characteristics					TOP configuration set-up			total	optional	
	volume liters	Le x h cm	pumps			tank	delivery pipes	pump		check valve	electric panel
			n.	power kW	delivery DN				€		
MNX TOP 0651 L055ZM PA	650	Ø 100 x 120	1	0,55	50	1.190,00	815,00	740,00	2.745,00	169,00	290,00
MNX TOP 0652 L055ZM PA			2			1.190,00	1.450,00	1.480,00	4.120,00	338,00	335,00
MNX TOP 0651 L110MM PA			1	1,10	50	1.190,00	815,00	965,00	2.970,00	169,00	290,00
MNX TOP 0652 L110MM PA			2			1.190,00	1.450,00	1.930,00	4.570,00	338,00	335,00
MNX TOP 0801 L110BM PA	800	Ø 100 x 140	1	1,10	50	1.370,00	835,00	980,00	3.185,00	169,00	290,00
MNX TOP 0802 L110BM PA			2			1.370,00	1.490,00	1.960,00	4.820,00	338,00	335,00
MNX TOP 0801 L120DM PA			1	1,20	50	1.370,00	835,00	1.325,00	3.530,00	169,00	290,00
MNX TOP 0802 L120DM PA			2			1.370,00	1.490,00	2.650,00	5.510,00	338,00	335,00
MNX TOP 1001 L150MM PA	1000	Ø 100 x 170	1	1,50	50	1.600,00	865,00	1.000,00	3.465,00	169,00	290,00
MNX TOP 1002 L150MM PA			2			1.600,00	1.550,00	2.000,00	5.150,00	338,00	335,00
MNX TOP 1001 L150ZM PA			1	1,50	50	1.600,00	865,00	1.300,00	3.765,00	169,00	290,00
MNX TOP 1002 L150ZM PA			2			1.600,00	1.550,00	2.600,00	5.750,00	338,00	335,00
MNX TOP 1201 L150BM PA	1200	Ø 100 x 200	1	1,50	50	1.805,00	965,00	905,00	3.675,00	169,00	290,00
MNX TOP 1202 L150BM PA			2			1.805,00	1.715,00	1.810,00	5.330,00	338,00	335,00
MNX TOP 1201 L110AM PA			1	1,10	50	1.805,00	965,00	930,00	3.700,00	169,00	290,00
MNX TOP 1202 L110AM PA			2			1.805,00	1.715,00	1.860,00	5.380,00	338,00	335,00
MNX TOP 1451 L150ZT PA	1450	Ø 100 x 230	1	1,50	50	2.010,00	990,00	1.300,00	4.300,00	169,00	385,00
MNX TOP 1452 L150ZT PA			2			2.010,00	1.770,00	2.600,00	6.380,00	338,00	470,00

MAXISOL MXS



WHERE TO USE IT



Lifting station Maxisol is generally used for lifting rainwater, dirty water and sewage containing solids of modest size and bringing such waters to a suitable distance.

INSTALLATION SCHEME

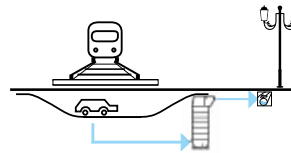

KEY

- ① Tank
- ② Lids for inspection tank and valve chamber
- ③ Stainless steel anti-intrusion grid (optional)
- ④ Sewage inlet pipe
- ⑤ Quick coupling foot
- ⑥ Stainless steel pump guide pipes
- ⑦ Chain and carabiners for pump lifting
- ⑧ PE pump delivery pipes
- ⑨ Pumped liquid outlet pipe
- ⑩ Float switches
- ⑪ Submersible pump
- ⑫ Valve chamber
- ⑬ Cast iron ball check valve
- ⑭ Flat body gate valve
- ⑮ Stainless steel screening basket (optional)

FUNCTION AND USE

Lifting station MAXISOL consists of a polyethylene tank with shaped bottom, with the function of collecting and bringing rainwater or wastewater to a higher level.

Inside there is a pumping system controlled by floats and electric panel. It can be equipped with pre-assembled valve chamber. The system is suitable for lifting medium size units with maximum delivery diameters DN 80.

TECHNICAL TABLE - PRICE LIST

model	dimensional characteristics					TOP configuration set-up				model TOP	electric panel
	volume liters	Le2 x W x h cm	pumps			tank	delivery pipes	pump	valve chamber		
			n.	power kW	delivery DN					€	€
MXS TOP 1201 L110MT CVVS	1.200	150 x 125 x 140	1	1,10	50	3.350,00	865,00	965,00	1.650,00	6.830,00	385,00
MXS TOP 1202 L110MT CVVS			2			3.350,00	1.550,00	1.860,00	2.290,00	9.050,00	470,00
MXS TOP 1201 L150ZM CVVS			1	1,50	50	3.350,00	865,00	1.300,00	1.650,00	7.165,00	290,00
MXS TOP 1202 L150ZM CVVS			2			3.350,00	1.550,00	2.600,00	2.290,00	9.790,00	335,00
MXS TOP 1201 L180ZT CVVS			1	1,80	65	3.350,00	1.220,00	1.580,00	1.720,00	7.870,00	385,00
MXS TOP 1202 L180ZT CVVS			2			3.350,00	2.260,00	3.160,00	2.440,00	11.210,00	470,00
MXS TOP 1701 L110BM CVVS	1.700	150 x 125 x 185	1	1,10	50	4.030,00	885,00	980,00	1.650,00	7.545,00	290,00
MXS TOP 1702 L110BM CVVS			2			4.030,00	1.600,00	1.960,00	2.290,00	9.880,00	335,00
MXS TOP 1701 L180DT CVVS			1	1,50	65	4.030,00	1.255,00	2.035,00	1.720,00	9.040,00	385,00
MXS TOP 1702 L180DT CVVS			2			4.030,00	2.340,00	4.070,00	2.440,00	12.880,00	470,00
MXS TOP 1701 T300MT CVVS			1	3,00	50	4.030,00	885,00	2.900,00	1.650,00	9.465,00	385,00
MXS TOP 1702 T300MT CVVS			2			4.030,00	1.600,00	5.800,00	2.290,00	13.720,00	470,00
MXS TOP 2201 L120DM CVVS	2.200	150 x 125 x 230	1	1,20	50	4.740,00	930,00	1.325,00	1.650,00	8.645,00	290,00
MXS TOP 2202 L120DM CVVS			2			4.740,00	1.690,00	2.650,00	2.290,00	11.370,00	335,00
MXS TOP 2201 L220MT CVVS			1	2,20	65	4.740,00	1.335,00	2.265,00	1.720,00	10.060,00	385,00
MXS TOP 2202 L220MT CVVS			2			4.740,00	2.490,00	4.530,00	2.440,00	14.200,00	470,00
MXS TOP 2201 L400DT CVVS			1	4,00	80	4.740,00	1.665,00	4.590,00	1.995,00	12.990,00	385,00
MXS TOP 2202 L400DT CVVS			2			4.740,00	3.160,00	9.180,00	2.985,00	20.065,00	470,00
MXS TOP 2701 T150MT CVVS	2.700	150 x 125 x 275	1	1,50	50	5.390,00	980,00	1.955,00	1.650,00	9.975,00	385,00
MXS TOP 2702 T150MT CVVS			2			5.390,00	1.785,00	3.910,00	2.290,00	13.375,00	470,00
MXS TOP 2701 L300ZT CVVS			1	3,00	65	5.390,00	1.410,00	2.795,00	1.720,00	11.315,00	385,00
MXS TOP 2702 L300ZT CVVS			2			5.390,00	2.645,00	5.590,00	2.440,00	16.065,00	470,00
MXS TOP 2701 L550MT CVVS			1	5,50	80	5.390,00	1.765,00	4.385,00	1.995,00	13.535,00	385,00
MXS TOP 2702 L550MT CVVS			2			5.390,00	3.345,00	8.770,00	2.985,00	20.490,00	470,00
MXS TOP 3151 L150MT CVVS	3.150	150 x 125 x 320	1	1,50	50	7.030,00	1.080,00	1.000,00	1.650,00	10.760,00	385,00
MXS TOP 3152 L150MT CVVS			2			7.030,00	1.940,00	2.000,00	2.290,00	13.260,00	470,00
MXS TOP 3151 L220DT CVVS			1	2,20	65	7.030,00	1.520,00	2.360,00	1.720,00	12.630,00	385,00
MXS TOP 3152 L220DT CVVS			2			7.030,00	2.830,00	4.720,00	2.440,00	17.020,00	470,00
MXS TOP 3151 L550ZT CVVS			1	5,50	80	7.030,00	1.880,00	3.915,00	1.995,00	14.820,00	385,00
MXS TOP 3152 L550ZT CVVS			2			7.030,00	3.550,00	7.830,00	2.985,00	21.395,00	470,00

MAXISOL XL MXL

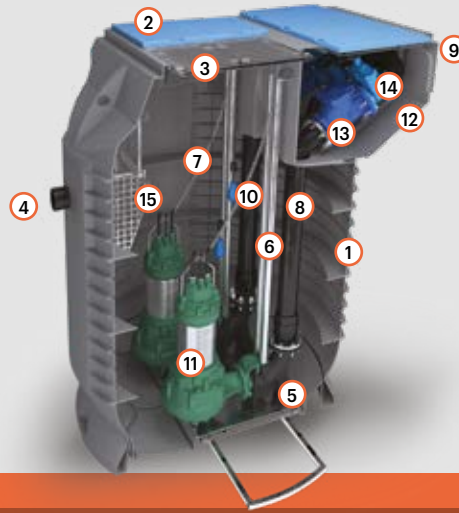

DOVE SI USA



Lifting station Maxisol XL is generally used for lifting rainwater, dirty water and sewage containing solids and bringing such waters to a suitable distance.

FUNCTION AND USE

Lifting station MAXISOL XL consists of a polyethylene tank with shaped bottom, with the function of collecting and bringing rainwater or wastewater to a higher level.

Inside there is a pumping system with pumps installed on quick coupling system, controlled by floats and electric panel. It can be equipped with pre-assembled valve chamber with single delivery collector including valved pipeline for pressing duct emptying. The system is suitable for lifting medium and big size units with maximum delivery diameters DN 150.

INSTALLATION SCHEME

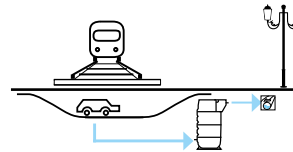

KEY

- ① Tank
- ② Lids for inspection tank and valve chamber
- ③ Stainless steel anti-intrusion grid (optional)
- ④ Sewage inlet pipe
- ⑤ Quick coupling foot
- ⑥ Stainless steel pump guide pipes
- ⑦ Chain and carabiners for pump lifting
- ⑧ Pumps delivery pipes
- ⑨ Pumped liquid outlet pipe
- ⑩ Float switches
- ⑪ Submersible pump
- ⑫ Valve chamber
- ⑬ Cast iron ball check valve
- ⑭ Flat body gate valve
- ⑮ Stainless steel screening basket (optional)

TECHNICAL TABLE - PRICE LIST

model	dimensional characteristics					TOP configuration set-up				model TOP	electric panel
	volume liters	Le2 x W x h cm	pumps n.	pumps		tank	delivery pipes	pump	valve chamber		
				power kW	delivery DN					€	€
MXL TOP 5801 L220ZT CVVS	5.800	278 x 228 x 207	1	2,20	65	14.460,00	1.520,00	2.445,00	4.925,00	23.350,00	385,00
MXL TOP 5802 L220ZT CVVS			2			14.460,00	2.830,00	4.890,00	6.520,00	28.700,00	470,00
MXL TOP 5803 L220ZT CVVS			3			14.460,00	3.005,00	7.335,00	7.810,00	32.610,00	1.000,00
MXL TOP 5801 L400DT CVVS			1	4,00	80	14.460,00	1.775,00	4.590,00	5.145,00	25.970,00	385,00
MXL TOP 5802 L400DT CVVS			2			14.460,00	3.320,00	9.180,00	7.040,00	34.000,00	470,00
MXL TOP 5803 L400DT CVVS			3			14.460,00	3.380,00	13.770,00	8.495,00	40.105,00	1.000,00
MXL TOP 8001 L180DT CVVS	8.000	278 x 228 x 267	1	1,80	65	17.345,00	1.655,00	2.035,00	4.925,00	25.960,00	385,00
MXL TOP 8002 L180DT CVVS			2			17.345,00	3.135,00	4.070,00	6.520,00	31.070,00	470,00
MXL TOP 8003 L180DT CVVS			3			17.345,00	3.410,00	6.105,00	7.810,00	34.670,00	1.000,00
MXL TOP 8001 L400MT CVVS			1	4,00	80	17.345,00	1.910,00	3.115,00	5.145,00	27.515,00	385,00
MXL TOP 8002 L400MT CVVS			2			17.345,00	3.625,00	6.230,00	7.040,00	34.240,00	470,00
MXL TOP 8003 L400MT CVVS			3			17.345,00	3.790,00	9.345,00	8.495,00	38.975,00	1.000,00
MXL TOP 10201 L600DT CVVS	10.200	278 x 228 x 327	1	6,00	80	20.330,00	2.105,00	4.965,00	5.145,00	32.545,00	385,00
MXL TOP 10202 L600DT CVVS			2			20.330,00	3.990,00	9.930,00	7.040,00	41.290,00	470,00
MXL TOP 10201 L300ZT CVVS			1	3,00	100	20.330,00	2.115,00	2.795,00	5.555,00	30.795,00	385,00
MXL TOP 10202 L300ZT CVVS			2			20.330,00	4.305,00	5.590,00	7.960,00	38.185,00	470,00
MXL TOP 10201 L750ZT CVVS			1	7,50	150	20.330,00	4.055,00	8.395,00	7.025,00	39.805,00	385,00
MXL TOP 10202 L750ZT CVVS			2			20.330,00	7.635,00	16.790,00	10.925,00	55.680,00	470,00
MXL TOP 12401 L550MT CVVS	12.400	278 x 228 x 387	1	5,50	80	21.915,00	2.275,00	4.385,00	5.145,00	33.720,00	385,00
MXL TOP 12402 L550MT CVVS			2			21.915,00	4.330,00	8.770,00	7.040,00	42.055,00	470,00
MXL TOP 12401 L400ZT CVVS			1	4,00	100	21.915,00	2.195,00	4.880,00	5.555,00	34.545,00	385,00
MXL TOP 12402 L400ZT CVVS			2			21.915,00	4.535,00	9.760,00	7.960,00	44.170,00	470,00
MXL TOP 12401 L552ZT CVVS			1	5,50	150	21.915,00	4.220,00	7.790,00	7.025,00	40.950,00	385,00
MXL TOP 12402 L552ZT CVVS			2			21.915,00	7.960,00	15.580,00	10.925,00	56.380,00	470,00
MXL TOP 14601 L550ZT CVVS	14.600	278 x 228 x 477	1	5,50	80	24.945,00	2.440,00	3.915,00	5.145,00	36.445,00	385,00
MXL TOP 14602 L550ZT CVVS			2			24.945,00	4.670,00	7.830,00	7.040,00	44.485,00	470,00
MXL TOP 14601 L551ZT CVVS			1	5,50	100	24.945,00	2.305,00	6.445,00	5.555,00	39.250,00	385,00
MXL TOP 14602 L551ZT CVVS			2			24.945,00	4.840,00	12.890,00	7.960,00	50.635,00	470,00
MXL TOP 14601 L900ZT CVVS			1	9,00	150	24.945,00	4.415,00	10.020,00	7.025,00	46.405,00	455,00
MXL TOP 14602 L900ZT CVVS			2			24.945,00	8.360,00	20.040,00	10.925,00	64.270,00	755,00

HYDRAULICS | LIFTING STATIONS

CORRUGATED SOL CC

FREE PUMP

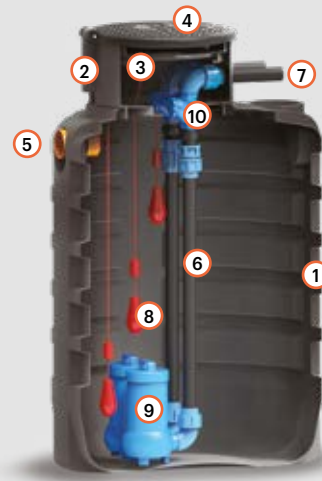

WHERE TO USE IT



Lifting station is generally used downstream of discharges for lifting rainwater, dirty water and sewage containing solids of modest dimensions and bringing such waters to a suitable distance.

FUNCTION AND USE

Lifting station CORRUGATED consists of a monoblock polyethylene tank, with the function of collecting and bringing rainwater or wastewater to a higher level.

Inside there is a pumping system controlled by floats and electric panel. It can be equipped with a quick coupling system or with free pump. The system is suitable for lifting small and medium size units with maximum delivery diameters 2" (or DN 50).

WHERE TO USE IT

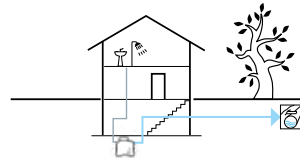

KEY

- ① Tank
- ② Inspection turret Ø 600
- ③ Bayonet cap Ø 600
- ④ Folding lid
- ⑤ Sewage inlet pipe
- ⑥ Pump delivery pipes
- ⑦ Pumped liquid outlet pipes
- ⑧ Float switches
- ⑨ Submersible pump
- ⑩ Cast iron ball check valve

TECHNICAL TABLE - PRICE LIST

COMPLETE TOP CONFIGURATION PRICE LIST - FREE PUMP

model	dimensional characteristics					TOP configuration set-up			total	optional		
	volume liters	Le cm	x W cm	x h n.	pumps		tank	delivery pipes €		pump	check valve €	electric panel €
					power KW	delivery "						
SOL CC 1001 L060MM PL	1.050	Ø 130	x 136	1	0,60	1"1/4	1.610,00	110,00	575,00	2.295,00	143,00	290,00
SOL CC 1002 L060MM PL				2			1.610,00	520,00	1.150,00	3.280,00	286,00	335,00
SOL CC 1001 L075AM PL				1	0,75	1"1/2	1.610,00	130,00	590,00	2.330,00	146,00	290,00
SOL CC 1002 L750AM PL				2			1.610,00	563,00	1.180,00	3.353,00	292,00	335,00
SOL CC 1601 L075MM PL	1.900	Ø 130	x 211	1	0,75	1"1/2	2.150,00	130,00	615,00	2.895,00	146,00	290,00
SOL CC 1602 L075MM PL				2			2.150,00	563,00	1.230,00	3.943,00	292,00	335,00
SOL CC 1601 L110AM PL				1	1,10	2"	2.150,00	176,00	930,00	3.256,00	169,00	290,00
SOL CC 1602 L110AM PL				2			2.150,00	656,00	1.860,00	4.666,00	338,00	335,00
SOL CC 2001 L060AM PL	2.150	Ø 130	x 233	1	0,60	1"1/2	2.470,00	130,00	535,00	3.135,00	146,00	290,00
SOL CC 2002 L060AM PL				2			2.470,00	563,00	1.070,00	4.103,00	292,00	335,00
SOL CC 2001 L110MM PL				1	1,10	2"	2.470,00	176,00	965,00	3.611,00	169,00	290,00
SOL CC 2002 L110MM PL				2			2.470,00	656,00	1.930,00	5.056,00	338,00	335,00
SOL CC 3001 L037ZM PL	3.300	Ø 165	x 211	1	0,37	1"1/2	3.545,00	130,00	560,00	4.235,00	146,00	290,00
SOL CC 3002 L037ZM PL				2			3.545,00	563,00	1.120,00	5.228,00	292,00	335,00
SOL CC 3001 L110AM PL				1	1,10	2"	3.545,00	176,00	930,00	4.651,00	169,00	290,00
SOL CC 3002 L110AM PL				2			3.545,00	656,00	1.860,00	6.061,00	338,00	335,00
SOL CC 3501 L120DM PL	3.700	Ø 165	x 233	1	1,20	2"	3.680,00	176,00	1.325,00	5.181,00	169,00	290,00
SOL CC 3502 L120DM PL				2			3.680,00	656,00	2.650,00	6.986,00	338,00	335,00

HYDRAULICS | LIFTING STATIONS

CORRUGATED SOL CC

PUMP AND COUPLING FOOT

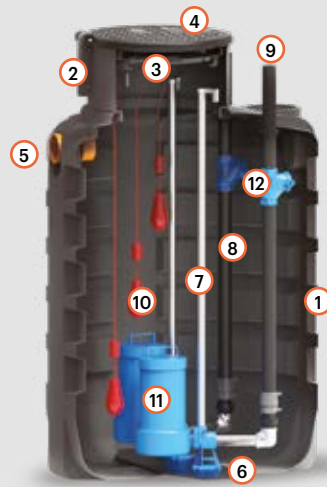

WHERE TO USE IT



Lifting station is generally used downstream of discharges for lifting rainwater, dirty water and sewage containing solids of modest dimensions and bringing such waters to a suitable distance.

INSTALLATION SCHEME

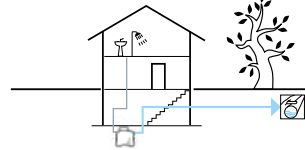

KEY

- ① Tank
- ② Inspection turret Ø 600
- ③ Bayonet cap Ø 600
- ④ Folding lid
- ⑤ Sewage inlet pipe
- ⑥ Quick coupling foot
- ⑦ Pump guide pipes
- ⑧ Pump delivery pipes
- ⑨ Pumped liquid outlet pipes
- ⑩ Float switches
- ⑪ Submersible pump
- ⑫ Cast iron ball check valve

FUNCTION AND USE

Lifting station CORRUGATED consists of a monoblock polyethylene tank, with the function of collecting and bringing rainwater or wastewater to a higher level.

Inside there is a pumping system controlled by floats and electric panel. It can be equipped with a quick coupling system or with free pump. The system is suitable for lifting small and medium size units with maximum delivery diameters 2" (or DN 50).

TECHNICAL TABLE - PRICE LIST

COMPLETE TOP CONFIGURATION PRICE LIST - PUMP AND COUPLING FOOT

model	dimensional characteristics						top configuration set-up			total	optional				
	volume liters	Le	x	W	x	h	pumps		tank		delivery pipes	pump	check valve*	electric panel	
							power n.	delivery kW DN							€
SOL CC 1001 L055ZM PA	1.050	Ø 130	x	136	x	136	1	0,55	50	1.610,00	815,00	740,00	3.165,00	169,00	290,00
SOL CC 1002 L055ZM PA							2			1.610,00	1.450,00	1.480,00	4.540,00	338,00	335,00
SOL CC 1001 L110MM PA							1	1,10	50	1.610,00	815,00	965,00	3.390,00	169,00	290,00
SOL CC 1002 L110MM PA							2			1.610,00	1.450,00	1.930,00	4.990,00	338,00	335,00
SOL CC 1601 L110BM PA	1.900	Ø 130	x	211	x	211	1	1,10	50	2.150,00	875,00	980,00	4.005,00	169,00	290,00
SOL CC 1602 L110BM PA							2			2.150,00	1.575,00	1.960,00	5.685,00	338,00	335,00
SOL CC 1601 L120DM PA							1	1,20	50	2.150,00	875,00	1.325,00	4.350,00	169,00	290,00
SOLCC 1602 L120DM PA							2			2.150,00	1.575,00	2.650,00	6.375,00	338,00	335,00
SOL CC 2001 L150MM PA	2.150	Ø 130	x	233	x	233	1	1,50	50	2.470,00	970,00	1.000,00	4.440,00	169,00	290,00
SOL CC 2002 L150MM PA							2			2.470,00	1.730,00	2.000,00	6.200,00	338,00	335,00
SOL CC 2001 L150ZM PA							1	1,50	50	2.470,00	970,00	1.300,00	4.740,00	169,00	290,00
SOL CC 2002 L150ZM PA							2			2.470,00	1.730,00	2.600,00	6.806,00	338,00	335,00
SOL CC 3001 L150BM PA	3.300	Ø 165	x	211	x	211	1	1,50	50	3.545,00	875,00	905,00	5.325,00	169,00	290,00
SOLCC 3002 L150BM PA							2			3.545,00	1.575,00	1.810,00	6.930,00	338,00	335,00
SOLCC 3001 L110AM PA							1	1,10	50	3.545,00	875,00	930,00	5.350,00	169,00	290,00
SOL CC 3002 L110AM PA							2			3.545,00	1.575,00	1.860,00	6.980,00	338,00	335,00
SOL CC 3501 L150ZT PA	3.700	Ø 165	x	233	x	233	1	1,50	50	3.680,00	970,00	1.300,00	5.950,00	169,00	385,00
SOL CC 3502 L150ZT PA							2			3.680,00	1.730,00	2.600,00	8.010,00	338,00	470,00

* supplied separated by the tank

FIRE-FIGHTING PLANT OFFIRE



WHERE TO USE IT



In all buildings used for production and commercial activities that fall within the classification of the standard for fire risk.

INSTALLATION SCHEME

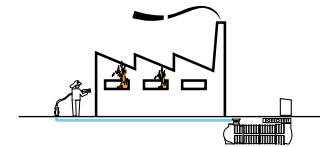

FUNCTION AND USE

Fire-fighting plant Offire consisting of underground polyethylene tank as water storage and pressurization plant with vertical pumps and command/control cabinet for:

- ensuring for a certain period water availability for buildings
- inhibiting fire and smoke propagation inside the building and neighbouring buildings.

STANDARDS AND CERTIFICATIONS

Compliant with standards:

EN 12845

UNI/TR 11438 (additional instructions to Standard UNI EN 12845), establishing that:

- **horizontal centrifugal pumps installed underground must be used**
- **the only vertical pumps allowed are "vertical turbine pumps"**
- **installations having submersible pumps and overground horizontal centrifugal pumps should be avoided and only used where an underground alternative is not possible.**

TECHNICAL TABLE - PRICE LIST

OFF..EP

model	tank volume liters	tanks n.	water reserve			command cabinet			flow rate m³/h	delivery DN	€		
			Le	W	h	Lu1	La1	h1			4 bar	6 bar	8 bar
			cm			cm							
OFF 18000 EP ..	18.980	1 x 18.000	620	x 210	x 275	245	x 100	x 145	18	80	47.305,00	51.065,00	52.225,00
OFF 24000 EP ..	25.200	1 x 24.000	800	x 210	x 275				24	80	50.755,00	54.515,00	55.675,00
OFF 36000 EP ..	37.650	1 x 36.000	1.160	x 210	x 275				36	80	60.280,00	63.140,00	65.750,00
OFF 48000 EP ..	50.100	2 x 24.000	800	x 470	x 275				48	80	71.160,00	72.150,00	74.070,00
OFF 60000 EP ..	62.840	2 x 30.000	980	x 470	x 275				60	80	78.960,00	81.060,00	83.810,00
OFF 72000 EP ..	75.300	2 x 36.000	1.160	x 470	x 275				72	100	90.315,00	95.710,00	99.090,00
OFF 90000 EP ..	94.260	3 x 30.000	980	x 730	x 275				90	100	101.130,00	109.470,00	110.325,00
OFF 108000 EP ..	112.950	3 x 36.000	1.160	x 730	x 275				108	125	117.930,00	125.495,00	127.095,00
OFF 120000 EP ..	131.610	3 x 42.000	1.340	x 730	x 275				120	125	145.060,00	146.460,00	150.550,00

OFF..EEP

OFF 18000 EEP ..	18.980	1 x 18.000	620	x 210	x 275	245	x 100	x 145	18	80	62.875,00	70.710,00	72.050,00
OFF 24000 EEP ..	25.200	1 x 24.000	800	x 210	x 275				24	80	66.325,00	73.620,00	75.500,00
OFF 36000 EEP ..	37.650	1 x 36.000	1.160	x 210	x 275				36	80	76.530,00	82.015,00	86.800,00
OFF 48000 EEP ..	50.100	2 x 24.000	800	x 470	x 275				48	80	89.860,00	91.600,00	95.005,00
OFF 60000 EEP ..	62.840	2 x 30.000	980	x 470	x 275				60	80	97.660,00	101.620,00	106.685,00
OFF 72000 EEP ..	75.300	2 x 36.000	1.160	x 470	x 275				72	100	110.215,00	120.775,00	127.100,00
OFF 90000 EEP ..	94.260	3 x 30.000	980	x 730	x 275				90	100	121.030,00	137.475,00	138.755,00
OFF 108000 EEP ..	112.950	3 x 36.000	1.160	x 730	x 275				108	125	139.470,00	154.365,00	157.130,00
OFF 120000 EEP ..	131.610	3 x 42.000	1.340	x 730	x 275				120	125	173.935,00	176.495,00	184.245,00

OFF..EMP

OFF 18000 EMP ..	18.980	1 x 18.000	620	x 210	x 275	378	x 100	x 145	18	80	82.215,00	89.435,00	91.315,00
OFF 24000 EMP ..	25.200	1 x 24.000	800	x 210	x 275				24	80	85.665,00	92.885,00	94.765,00
OFF 36000 EMP ..	37.650	1 x 36.000	1.160	x 210	x 275				36	80	95.685,00	101.280,00	110.855,00
OFF 48000 EMP ..	50.100	2 x 24.000	800	x 470	x 275				48	80	109.125,00	111.730,00	119.065,00
OFF 60000 EMP ..	62.840	2 x 30.000	980	x 470	x 275				60	80	116.925,00	121.060,00	128.845,00
OFF 72000 EMP ..	75.300	2 x 36.000	1.160	x 470	x 275				72	100	130.625,00	143.220,00	146.335,00
OFF 90000 EMP ..	94.260	3 x 30.000	980	x 730	x 275				90	100	141.440,00	156.715,00	157.990,00
OFF 108000 EMP ..	112.950	3 x 36.000	1.160	x 730	x 275				108	125	163.025,00	177.430,00	181.215,00
OFF 120000 EMP ..	131.610	3 x 42.000	1.340	x 730	x 275				120	125	197.000,00	200.580,00	209.265,00

HYDRAULICS | FIRE-FIGHTING

FIRE-FIGHTING WATER STORAGE TANK OVERGROUND



WHERE TO USE IT



In the case of overground pressurisation units usage in all buildings used for production and commercial activities that fall within the classification of the standard for fire risk.

INSTALLATION SCHEME

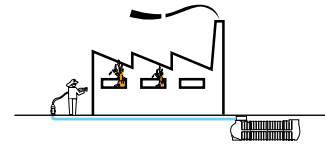

FUNCTION AND USE















The tanks for overground installation have the function of storing a water reserve which is enough to meet the requirements of a fire-fighting pressurisation plant, in case overground pressurization units are used.

They can be equipped with pipes and accessories required by the pressurisation units configuration and by the entire design of the system.

STANDARDS AND CERTIFICATIONS

All the equipments of the tanks are compliant with standard:
EN 12845

TECHNICAL TABLE - PRICE LIST

icon	model	volume	tanks		Le x W x h		caps Ø cm	h max (with turret)	€
		liters	n.	code	cm	cm	60	cm	
	SEI M 12000 AGA	12.750	1	SEI M 12000 AG	440 x 210 x 234	1	285	8.170,00	
	SEI M 18000 AGA	18.980	1	SEI M 18000 AG	620 x 210 x 234	1	285	12.970,00	
	SEI M 24000 AGA	25.200	1	SEI M 24000 AG	800 x 210 x 234	1	285	16.420,00	
	SEI M 30000 AGA	31.420	1	SEI M 30000 AG	980 x 210 x 234	1	285	20.320,00	
	SEI M 36000 AGA	37.650	1	SEI M 36000 AG	1.160 x 210 x 234	1	285	25.270,00	
	SEI M 42000 AGA	43.870	1	SEI M 42000 AG	1.340 x 210 x 234	1	285	31.870,00	
	SEI M 48000 AGA	50.400	1	SEI M 48000 AG	1.520 x 210 x 234	1	285	35.920,00 *	
	SEI M 60000 AGA	62.840	2	SEI M 30000 AG	980 x 210 x 234	3	285	42.770,00	
	SEI M 72000 AGA	75.300	2	SEI M 36000 AG	1.160 x 210 x 234	3	285	52.670,00	
	SEI M 84000 AGA	87.740	2	SEI M 42000 AG	1.340 x 210 x 234	3	285	65.870,00	
	SEI M 90000 AGA	94.260	3	SEI M 30000 AG	980 x 210 x 234	5	285	64.120,00	
	SEI M 96000 AGA	100.200	2	SEI M 48000 AG	1.520 x 210 x 234	3	285	73.970,00 *	
	SEI M 108000 AGA	112.950	3	SEI M 36000 AG	1.160 x 210 x 234	5	285	78.970,00	
	SEI M 120000 AGA	131.610	3	SEI M 42000 AG	1.340 x 210 x 234	5	285	98.770,00	

Prices are inclusive of overflow and sockets Ø 250 for connecting several tanks in parallel.

* Mounting on site not included.



SPECIFIC SECTORS

The manufacturing of polyethylene products through rotational moulding can be applied not only to water treatment and water recovery but also to other market sectors. This technique allows the production of even large dimension artifacts at a relatively low cost.

DI CAMILLO SERBATOI product lines also includes one called "Specific Sectors"

which refer to the following fields:

Building / Roads

Transportable diesel tanks / Dredging

Products manufactured are listed below.



BUILDING



- hopper
- rubble-discharge tube

- case

ROAD



- barriers

- road barriers

- bollards

DIESEL TANKS



- transportable tanks startank

- industrial tanks for generators

- AdBlue

DREDGING



- floats

SPECIFIC SECTORS

BUILDING PRODUCTS



RUBBLE-DISCHARGE TUBE



HOPPER



STACKABLE HOPPER



CASE

FUNCTION AND USE



Complete system made of yellow PE used on construction sites for conveying construction rubble from upper floors to the ground floor of the building.



Yellow-color polyethylene tool case without joints or welds, with hinges and padlockable closure, ideal as a container for multiple use, in particular for storing tools and various on-site equipment.

STANDARDS AND CERTIFICATIONS

There are no Standards that determine the design characteristics of these products, however they are subject to the following rules:



Galvanize steel chains:
certified according to traction tests.











Galvanized steel support for hopper:
Do not exceed the installation of a maximum number of rubble-discharge tubes equal to 6. When this value is exceeded, put an additional hopper with support in the discharge column.



Galvanized steel retarder: to be positioned inside the conveyor tube in order to slow down the fall of rubble.

TECHNICAL TABLE - PRICE LIST

icon	model	description	L	La	L1	L2	a	b	h	weight	packaging		€
			cm								kg	type	
	ED TPS 1000 G	rubble-discharge tube (chains included)	70	-	39	58	-	-	105	9	pallet	36	90,00
	ED TRA 1000 G	hopper	69	-	-	58	36	96	101	14	pallet	5	160,00
	ED TRC 300 G	hopper cover	69	-	-	-	-	96	31	5	pallet	20	55,00
	ED TRI 700 G	stackable hopper	69	-	-	-	-	96	72	11	pallet	20	125,00
	ED STR 800 Z	hopper support	69	-	-	-	-	80	130	14	pallet	5	160,00
	ED BAU 180 G	case	85	45	-	-	-	-	52	12,5	single	1	240,00
	ED RAL 260 Z	retarder	45	-	-	-	-	-	26	1,5	single	1	60,00
	ED CAL 1100 Z	chains	-	-	-	-	-	-	110	0,75	single	1	15,00

ROAD PRODUCTS

- EXTRA-STACKABLE BARRIER
- BOLLARDS
- ROAD BARRIERS



EXTRA-STACKABLE BARRIER



STACKABLE ROAD BARRIER



BOLLARDS

FUNCTION AND USE



Extra-stackable barrier. It is produced in PE and guarantees constant thickness and monolithic artifact. Each barrier is equipped with a filling cap (pressurized) and a drain cap (threaded) for easy transport. The original patented design allows transport optimisation thanks to easy stacking. It is used for the limitation of certain areas, channeling of pedestrian or vehicular flows, blocking access.



Bollard. It is produced in linear HDPE. Each bollard is equipped with a threaded cap for loading and unloading. It is used for courtesy signals, outlining routes or prevent vehicles from parking. The central hole can be used to insert a signalling pole.

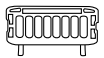

Stackable road barrier. Panels are produced in HDPE and equipped with an interlocking system that allows stacking up to a maximum of 40 barriers, facilitating the activity of storage. Feet (recycled PVC) are realized with a scalloped shaped design to prevent worker pedestrian accidents.

STANDARDS AND CERTIFICATIONS

There are no Standards that determine the design characteristics of these products, however they are subject to the following rules:

- Certification for UV protection of the raw material used for its realization

Aging tests to guarantee resistance to atmospheric agents.

The stackable barriers comply with BSO8442 (stability under wind conditions); they are supplied with reflecting bands according to EN 12899-1.

TECHNICAL TABLE - PRICE LIST

icon	model	Le x W x h cm	central hole of the pole mm	joint M/F	charge mm	discharge mm	color	weight		pallet packaging		€
								empty kg	full max	Le x W x h cm	qt.y n.	
	ST BSI 700 BR	100 x 40 x 70	-	-	60	3/4"	red	6,50	17	120 x 210 x 250	48*	110,00
	ST BSI 700 BB	100 x 40 x 70	-	-	60	3/4"	white	6,50	17	120 x 210 x 250	48*	110,00
	ST DIS 500 G	50 x 50 x 55	58	-	2"	-	yellow	5	70	-	1	105,00
	ST DIS 500 B	50 x 50 x 55	58	-	2"	-	marbled	5	70	-	1	105,00
	ST TRL 200	200 x 30 x 100	-	-	-	-	red	12	-	-	40	190,00

* packaging half red, half white

SPECIFIC SECTORS

TANK FOR DIESEL TRANSPORT STARTANK



TANK 230 LITRES



TANK 440 LITRES

KEY

- ① Folding lid with opening 95°
- ② Transfer pump
- ③ Electric cable with clamps
- ④ Digital flowmeter
- ⑤ Dispensing nozzle
- ⑥ Load cap
- ⑦ Diesel level gauge

FUNCTION AND USE

STARTANK tank is a transfer system designed for the storage, transport and related transfer of Diesel fuel on vehicles or mechanical devices in general.

It is made of linear polyethylene approved for diesel by rotational moulding with constant wall thickness in monolithic artifact.

The storage tank is equipped with a visible level indicator; a digital flowmeter with LCD display is installed on the delivery of the transfer pump.

The system is powered by connecting the 12 V direct current electrical equipment to the vehicle battery using special clamps.

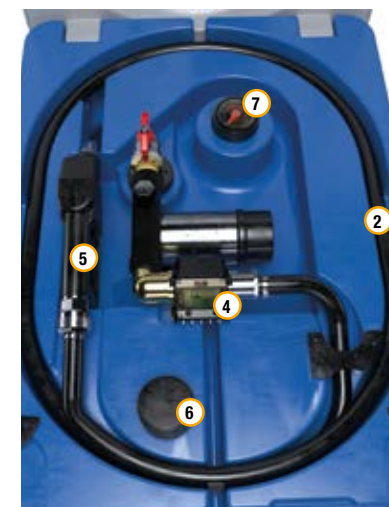
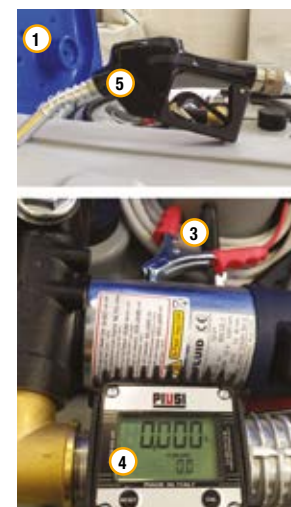

TECHNICAL TABLE - PRICE LIST

icon	model	Le x W x h	volume	empty weight	pump	flow rate	€
		mm	liters	kg	Volt	liters/min	
	SG STK D 230-12	600 x 800 x 700	230	35	12	40	2.035,00
	SG STK D 440-12	1200 x 700 x 800	440	55	12	40	2.555,00

Available on request also for AdBlue.

SPECIFIC SECTORS

TANK FOR AdBlue®



FUNCTION AND USE

The plant consists of a polyethylene tank, designed and built to allow correct and appropriate management of the product through a fully automatic transfer system with dispensing nozzle and digital flowmeter.

AdBlue® must always be poured into the tank dedicated to it, making sure that this is never filled with diesel.

WHY USING AdBlue®

The nitrogen oxides deriving from the combustion of diesel in vehicles are highly polluting for the air we breathe. In order to break down these pollutants, it is used a highly pure aqueous urea solution called AdBlue®. Thanks to a careful and thorough study of the evolution of this specific sector, DI CAMILLO SERBATOI has developed a product aimed at satisfying all market demands, as regards storage and delivery of AdBlue®. All the transfer and dispensing systems supplied by DI CAMILLO SERBATOI are designed and manufactured to ensure that the integrity of the product is maintained and at the same time to allow rapid operations in maximum safety.

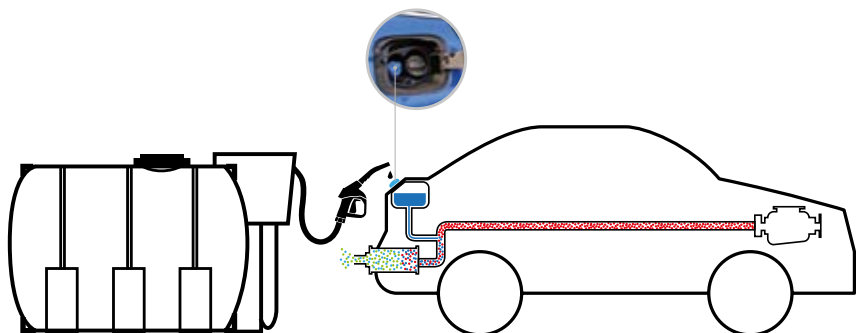

The compartment is entirely realized in PE by DI CAMILLO SERBATOI and it is used for housing:

Membrane electric pump for Adblue®
230V 50Hz 40 l/min

Plastic fittings
90° M/F 1" BSP

Turbine digital flowmeter
for AdBlue® MEC 24
min-max capacity
5-120 l/min

Automatic nozzle in
plastic edges in stainless
steel "AP80" per AdBlue®

Antistatic rubble
supply pipe
EPDM 20 bar 19x29

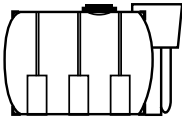

TECHNICAL TABLE - PRICE LIST

icon	model	volume liters	TANK				COMPARTMENT				COMPARTMENT COVER	€		
			dimensions Le x W x h cm			caps Ø 35 40 cm		vents Ø	pump di- mensions V	flowmeter type	supply pipe material		dispensing nozzle m	external visual level indicator
			visual h											
	ADB1000CT	1000	212 x 90 x 100	1	-	1	230	digitale	EPDM	3	40	2.720,00		
	ADB1500CT	1500	212 x 115 x 128	-	1	1	230	digitale	EPDM	3	64	2.870,00		
	ADB2000CT	2000	212 x 130 x 140	-	1	1	230	digitale	EPDM	3	80	3.160,00		
	ADB3000CT	3000	242 x 145 x 155	-	1	1	230	digitale	EPDM	3	93	3.720,00		
	ADB5000CT	5000	289 x 170 x 180	-	1	1	230	digitale	EPDM	3	120	4.380,00		

Available on request also for diesel.

SPECIFIC SECTORS

INDUSTRIAL TANKS FOR DIESEL



FUNCTION AND USE

Monolithic polyethylene tanks for diesel storage in a customizable shape that can be installed on generators, agricultural machinery, etc. The tanks can also be made for vehicles homologated for transport.

STANDARDS AND CERTIFICATIONS

Tanks for diesel storage installed on generators:

- Decreto Ministeriale 13 luglio 2011 e s.m.i.

Tanks on vehicles homologated for transport

- Homologation standard according to Regolamento n. 34 UN/ECE.



HIGH



BUILT-IN



SHORT



FOR VEHICLES



H-SHAPED

TECHNICAL TABLE - PRICE LIST SHORT RECTANGULAR TANK

icon	model	Le x W x h mm	arrangements											€	
			max. volume	charge	delivery	vent	return	discharge	overflow	floats connections	fixing straps ribs	pumps de-tection housing			
			liters	2"	1/2"	1/2"	1/2"	1/2"	1/2"	6 fori					
	SG MI RB 50--200	600 X 500 X 200	52	•	•	•	•	•	•	•	•	•	•	-	160,00
	SG MI RB 120-200	700 X 1000 X 200	122	•	•	•	•	•	•	•	•	•	•	-	295,00
	SG MI RB 400-200	850 X 2700 X 200	400	•	•	•	•	•	•	-	•	-	-	-	930,00
	SG MI RB 600-200	1100 X 3000 X 200	600	•	•	•	•	•	•	-	•	-	-	-	1.295,00

HIGH RECTANGULAR TANK

	SG MI RA 130-400	520 X 850 X 400	130	•	•	•	•	•	-	-	-	•	-	-	325,00
---	------------------	-----------------	-----	---	---	---	---	---	---	---	---	---	---	---	--------

H-SHAPED RECTANGULAR TANK

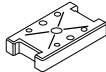
	SG MI RH 120-200	650 X 1130 X 210	120	•	•	•	•	•	•	•	•	•	•	•	315,00
	SG MI RH 240-200	800 X 1800 X 210	240	•	•	•	•	•	•	•	•	•	•	•	640,00
	SG MI RH 400-200	950 X 2450 X 210	400	•	•	•	•	•	•	•	•	•	•	•	965,00

BUILT-IN RECTANGULAR TANK

	SG MI RI 250-200	730 X 1830 X 200	246	•	•	•	•	•	-	-	-	-	-	•	665,00
	SG MI RI 400-300	730 X 1830 X 300	401	•	•	•	•	•	-	-	-	-	-	•	725,00
	SG MI RI 500-350	730 X 1830 X 350	468	•	•	•	•	•	-	-	-	-	-	•	775,00
	SG MI RI 600-450	730 X 1830 X 450	601	•	•	•	•	•	-	-	-	-	-	•	870,00
	SG MI RI 900-650	730 X 1830 X 650	868	•	•	•	•	•	-	-	-	-	-	•	1.010,00
	SG MI RI 1000750	730 X 1830 X 750	1002	•	•	•	•	•	-	-	-	-	-	•	1.105,00
	SG MI RI 1100800	730 X 1830 X 800	1069	•	•	•	•	•	-	-	-	-	-	•	1.215,00
	SG MI RI 1200900	730 X 1830 X 900	1202	•	•	•	•	•	-	-	-	-	-	•	1.325,00
	SG MI RI 300-200	730 X 2100 X 200	311	•	•	•	•	•	-	-	-	-	-	•	725,00
	SG MI RI 500-300	730 X 2100 X 300	466	•	•	•	•	•	-	-	-	-	-	•	820,00
	SG MI RI 550-350	730 X 2100 X 350	544	•	•	•	•	•	-	-	-	-	-	•	870,00
	SG MI RI 700-450	730 X 2100 X 450	700	•	•	•	•	•	-	-	-	-	-	•	945,00
	SG MI RI 1000650	730 X 2100 X 650	1011	•	•	•	•	•	-	-	-	-	-	•	1.120,00
	SG MI RI 1200750	730 X 2100 X 750	1166	•	•	•	•	•	-	-	-	-	-	•	1.245,00
	SG MI RI 1250800	730 X 2100 X 800	1244	•	•	•	•	•	-	-	-	-	-	•	1.355,00
	SG MI RI 1400900	730 X 2100 X 900	1399	•	•	•	•	•	-	-	-	-	-	•	1.500,00

TANK FOR VEHICLES

	SG AUTO 500-300	500 X 330 X 300	40	•	-	-	-	-	1/4"	-	•	•	-	-	145,00
---	-----------------	-----------------	----	---	---	---	---	---	------	---	---	---	---	---	--------

SPECIFIC SECTORS

DREDGING FLOATS



FUNCTION AND USE

Monolithic half-shell cylindrical float in PE, realized through rotational moulding technique.

In addition to constant wall thickness of 8/12 mm, such technique also guarantees excellent impact resistance and durability. They are available in the following versions: EMPTY or FOAMED with polyurethane foam density 35/100 Kg/m³ (choice based on the depth of water). They are normally used for the flotation of pipes in PE or other material, in dredging works in ports, lakes, dams, etc. Upon request, it is possible to use polyurethane foam with higher density in case of greater sea depths.

STANDARDS AND CERTIFICATIONS

There are no standards that determine the design characteristics of these products, however they are subjected to the following tests:

- Mechanical test on the part made in polyethylene
- Density test made on polyurethane foam cube



L550



L700



L1150





L1200









L1900







TECHNICAL TABLE - PRICE LIST









icon	model	dimensional values						V = Empty	S35 = Foamed	S55 = Foamed	S100 = Foamed	€			
		∅ internal	∅ external	Le	shells	half-shell volume	total volume	net thrust				Empty	Foamed (Kg. 35 m³)	Foamed (Kg. 50 m³)	Foamed (Kg. 100 m³)
		mm	mm	mm	n.	liters	liters	kg							
	DR GAL 55.45.110 ..	110	450	550	2	32	64	52,00	49,50	44,90	39,20	405,00	475,00	600,00	755,00
	DR GAL 55.45.125 ..	125	450	550	2	32	64	52,00	49,50	44,90	39,20	405,00	475,00	600,00	755,00
	DR GAL 55.45.140 ..	140	450	550	2	31	62	50,00	47,60	43,10	37,60	405,00	470,00	595,00	745,00
	DR GAL 55.45.160 ..	160	450	550	2	28	56	44,00	41,80	37,80	32,80	405,00	465,00	575,00	710,00
	DR GAL 70.80.180 ..	180	800	700	2	122	245	216,86	207,46	189,86	167,86	795,00	1.055,00	1.535,00	2.135,00
	DR GAL 70.80.200 ..	200	800	700	2	119	238	210,00	200,90	183,80	162,40	795,00	1.045,00	1.515,00	2.095,00
	DR GAL 70.80.225 ..	225	800	700	2	111	222	194,00	185,50	169,50	149,60	795,00	1.030,00	1.465,00	2.010,00
	DR GAL 70.80.250 ..	250	800	700	2	114	228	200,00	191,30	174,90	154,40	795,00	1.035,00	1.485,00	2.040,00
	DR GAL 70.100.280 ..	280	960	700	2	182	364	330,00	316,10	289,90	257,20	990,00	1.370,00	2.085,00	2.980,00
	DR GAL 70.100.315 ..	315	960	700	2	177	354	320,00	306,50	281,00	249,20	990,00	1.360,00	2.055,00	2.925,00
	DR GAL 70.100.355 ..	355	960	700	2	170	340	306,00	293,00	268,60	238,00	990,00	1.345,00	2.015,00	2.850,00
	DR GAL 70.140.400 ..	400	1.400	700	2	390	780	720,00	690,30	634,20	564,00	1.735,00	2.545,00	4.080,00	5.995,00
	DR GAL 70.140.450 ..	450	1.400	700	2	378	756	696,00	667,20	612,80	544,80	1.735,00	2.520,00	4.005,00	5.865,00
	DR GAL 70.140.500 ..	500	1.400	700	2	364	728	668,00	640,30	587,90	522,40	1.735,00	2.490,00	3.920,00	5.710,00
DR GAL 70.140.560 ..	560	1.400	700	2	347	694	634,00	607,60	557,60	495,20	1.735,00	2.455,00	3.820,00	5.525,00	
	DR GAL 120.75.180 ..	180	750	1.200	2	215	430	388,00	371,60	340,70	302,00	1.245,00	1.690,00	2.535,00	3.590,00
	DR GAL 120.75.225 ..	225	750	1.200	2	208	416	374,00	358,10	328,20	290,80	1.245,00	1.680,00	2.495,00	3.515,00
	DR GAL 120.75.250 ..	250	750	1.200	2	202	404	362,00	346,60	317,50	281,20	1.245,00	1.665,00	2.460,00	3.450,00
	DR GAL 120.85.280 ..	280	850	1.200	2	216	432	386,00	369,50	338,40	299,60	1.355,00	1.805,00	2.655,00	3.710,00
	DR GAL 120.85.315 ..	315	850	1.200	2	207	414	368,00	352,20	322,40	285,20	1.355,00	1.785,00	2.600,00	3.615,00
	DR GAL 120.85.350 ..	355	850	1.200	2	197	394	348,00	333,00	304,60	269,20	1.355,00	1.765,00	2.540,00	3.505,00
	DR GAL 120.85.400 ..	400	850	1.200	2	180	360	314,00	300,30	274,40	242,00	1.355,00	1.730,00	2.435,00	3.320,00
	DR GAL 120.125.400 ..	400	1.250	1.200	2	518	1.036	966,00	926,60	852,00	758,80	1.995,00	3.070,00	5.105,00	7.650,00
	DR GAL 120.125.450 ..	450	1.250	1.200	2	499	998	928,00	890,00	818,20	728,40	1.995,00	3.030,00	4.990,00	7.445,00
	DR GAL 120.125.500 ..	500	1.250	1.200	2	476	952	882,00	845,80	777,20	691,60	1.995,00	2.985,00	4.855,00	7.190,00
	DR GAL 120.125.560 ..	560	1.250	1.200	2	450	900	830,00	795,80	731,00	650,00	1.995,00	2.930,00	4.695,00	6.910,00
	DR GAL 120.125.630 ..	630	1.250	1.200	2	412	824	754,00	722,60	663,30	589,20	1.995,00	2.850,00	4.470,00	6.495,00
	DR GAL 120.150.630 ..	630	1.500	1.200	2	681	1.362	1.272,00	1.220,20	1.122,10	999,60	2.580,00	3.995,00	6.675,00	10.015,00
DR GAL 120.150.710 ..	710	1.500	1.200	2	625	1.250	1.160,00	1.112,50	1.022,50	910,00	2.580,00	3.880,00	6.335,00	9.405,00	











ACCESSORIES AND COMPONENTS



use					group code	group description	article		dimensional characteristics					description	€
biological	rainwater treatment	water recovery	hydraulics	icon			code	vol.	Le	W	h	Ø DN			
								liters	mm			mm			
X	X				POF	Inspection shaft		POF O 200 UNI125	200	600	600	800		Octagonal inspection shaft capacity 1t 200, compliant with the provisions of manual UNICHIM.	360,00
								POF O 200 UNI160	200	600	600	800			390,00
								POF O 125	150	600	600	570		Octagonal inspection shaft.	310,00
								POF O 160	150	600	600	570			345,00
								POF O 200	150	600	600	570			375,00
X	X				POR	Connection shaft		POR O 125	200	600	600	800		Octagonal connection shaft capacity 150 lt, nr. 3 inlet pipes and nr. 1 outlet pipe.	390,00
								POR O 160	200	600	600	800			505,00
								POR O 200	200	600	600	800			540,00
X					POC	Flow shaft		POC O 200	200	600	600	800		Octagonal flow shaft capacity 1t 200 with inlet pipe Ø125 and outlet pipe Ø80	660,00
								POC L 400	300	800	800	690		Smooth flow shaft capacity 1t 500 with inlet pipe Ø125 and outlet pipe Ø 80	720,00
								POC L 500	500	800	800	1.090		Smooth flow shaft capacity 1t 400 with inlet pipe Ø125 and outlet pipe Ø80	820,00
								POC S 600	600	1.040	780	1.010		Narrow flow shaft capacity 1t 600 with inlet pipe Ø160 and outlet pipe Ø 80	1.090,00
								POC S 750	750	1.040	780	1.300		Narrow flow shaft capacity 1t 750 with inlet pipe Ø 160 and outlet pipe Ø 80	1.140,00
X					PCL	Chlorinator shaft		PCL O 125	150	600	600	570		Octagonal chlorinator shaft capacity 1t 150, pipes IN/OUT Ø 125 mm	375,00
								PCL O 160	150	600	600	570		Octagonal chlorinator shaft capacity 1t 150, pipes IN/OUT Ø 160 mm	430,00
	X				SCM P	Small spillway shaft		SCM P 125/125		1.040	790	430		Spillway shaft equipped with three sockets for inlet, outlet and by-pass. The outlets are equipped with telescopic sockets for adjustment to pipes. Inside the shaft there is a deflector sized according to the dimensions of the outlet pipe. The shaft is also equipped with manhole in polymeric material 400x400 B125.	790,00
								SCM P 160/160		1.040	790	430			805,00
								SCM P 200/200		1.040	790	430			810,00
								SCM P 250/250		1.040	790	430			775,00
X					PGR	Manual screening shaft		PGR O 200	200	600	600	800		Octagonal screening shaft capacity 200 lt, IN/OUT Ø 125 mm.	900,00
								PGR S 750	750	1.040	780	1.300		Narrow screening shaft capacity 750 lt, IN/OUT Ø 160 mm.	2.120,00







use				group code	group description	article		dimensional characteristics				description	€		
biological	rainwater treatment	water recovery	hydraulics			icon	code	vol.	Le	W	h			Ø DN	
								liters	mm					mm	
	X			SCM G	Big spillway shaft		SCM G 315/315		1.780	1.450	880		1.770,00		
							SCM G 400/400		1.780	1.450	880		1.800,00		
							SCM G 500/500		1.780	1.450	880		2.320,00		
							SCM G 630/630		1.780	1.450	880		2.670,00		
X				VDS	Dispersing tank		VDS CC 800	840	1.300	1.300	1.030		930,00		
							VDS CC 1200	1.180	1.300	1.300	1.330		1.030,00		
							VDS CC 1600	1.680	1.300	1.300	1.780		1.215,00		
	X			POA	Oil-absorbing tank		POA C 800	840	1.300	1.300	970		1.440,00		
							POA C 2000	1.920	1.300	1.300	1.940		2.445,00		
							POA C 4500	4.500	1.950	1.950	1.820		5.850,00		
X				FCC	Screw filter		FCC Y 100 AUT		1.450		900		10.000,00		
			X	CLL PE	Screening basket in PE BabySol		CLL Y BBS 100 PE				300	100	40,00		
							CLL Y BBS 200 PE						500	100	60,00
			X	CLL IX	Screening basket in stainless steel		CLL Y BBS 100 IX				300	100	140,00		
							CLL Y BBS 200 IX						500	100	160,00
							CLL MXS Y 500				500	300	800		1.125,00
							CLL MXL Y 700				770	400	900		1.910,00
X	X	X	X	PRO RQ	Round/squared extension		PRO RQ X 400/40		400	400	220	220	Rectangular/squared lifting extension for inserting commercial shaft in PVC.	120,00	
							PRO RQ X 400/40 TPP				400	400	220	220	Rectangular/squared lifting extension for inserting commercial shaft in PVC with upper cap.









X	X	X	X	PRO	Circular extension		PRO X 200	200	200	300		Lifting extension in PE Ø 200, h 300 mm.	70,00	
							PRO X 400	400	400	300		Lifting extension in PE Ø 400, h 300 mm.	105,00	
							PRO X 600	600	600	300		Lifting extension in PE Ø 600, h 300 mm.	290,00	
X	X	X	X	PRO MD	Rectangular extension for modular tanks		PRO MD X 1200-10	1.200	800	100		Lifting turret to install on oval hatch of modular tanks for inspection and maintenance normally used for oil separation compartments.	525,00	
							PRO MD X 1200-50	1.200	800	500			585,00	
			X	PRO IAP	Extension for housing system Bioblu		PRO X 630 IAP	630	630	100		Extension in polyethylene with housing for pressure pipes passing holes	120,00	
X	X	X	X	SSM	Saddles for tanks placement		SSM Y 2100	810	2.450		880	Saddle in galvanized steel for overground installation of modular tank.	1.570,00	
							SSMP Y 1250	1.150	1.730		620	Saddle in painted steel for overground installation of small modular tank.	1.395,00	
X	X			CNC	Cone for pumps housing		CNC X 112	690	690	1.120		Container in polyethylene with truncated cone shape normally used for housing electric pumps with predisposition for closing cap diameter 600 mm.	310,00	
							CNC X 130	690	690	1.300			335,00	
X	X	X	X	TTP	Caps		TTP Y 140 BM				140		Bayonet cap Ø 140 mm.	14,00
							TTP Y 200 BM				200		Threaded cap Ø 200 mm male.	22,00
							TTP Y 300 BF				300		Bayonet cap Ø 300 mm female.	57,00
							TTP Y 400 BM				400		Bayonet cap Ø 400 mm.	57,00
							TTP Y 400 BF				400		Bayonet cap Ø 400 mm female.	64,00
							TTP Y 620 BM				620		Bayonet cap Ø 620 mm.	68,00
							TTP X 750 R				750		Folding lid Ø 750 mm.	115,00
							TTP X 75-80	750	500				Rectangular lid with key lock.	160,00
X	X	X	X	CHI	Telescopic manhole in polymeric material		CHI Y 400-200	300	300	115	250	Tilting telescopic manhole Class B125 extension inlet Ø 200.	190,00	
							CHI Y 600-400	500	500	160	400	Tilting telescopic manhole Class B125 extension inlet Ø 400.	405,00	
							CHI Y 800-600	840	840	225	630	Tilting telescopic manhole Class B125 extension inlet Ø 600.	895,00	
			X	CHI MX	Frame and vehicular manhole Maxisol		CHI Y 400 MXS	2.500	1.000	160		Manholes support frame lifting station Maxisol (MXS) for vehicular passage D 400 with manhole in polymeric material.	6.430,00	
							CHI Y 400 MXL	3.000	1.900	165		Manholes support frame lifting station Maxisol XL (MXL) for vehicular passage D 400 with manhole in polymeric material.	10.250,00	











use				group code	group description	article		dimensional characteristics				description	€		
biological	rainwater treatment	water recovery	hydraulics			icon	code	vol.	Le	W	h			Ø DN	
								liters		mm				mm	
X	X	X	X	TUB EL	In/out pipe for electro-welded connection		TUB Y 63 EL					50	Electro-welded PE pipe for connection.	130,00	
							TUB Y 75 EL							65	135,00
							TUB Y 90 EL							80	145,00
							TUB Y 110 EL							100	155,00
							TUB Y 125 EL							125	165,00
							TUB Y 160 EL							150	185,00
							TUB Y 200 EL							200	245,00
							TUB Y 250 EL							250	320,00
X	X	X	X	TUB F	In/out pipe for flanged electro-welded connection		TUB Y 63 F					50	Connection socket in PE electro-welded to the tank with flanged connection.	255,00	
							TUB Y 75 F							65	280,00
							TUB Y 90 F							80	300,00
							TUB Y 110 F							100	335,00
							TUB Y 125 F							125	385,00
							TUB Y 160 F							150	460,00
							TUB Y 200 F							200	680,00
							TUB Y 250 F							250	1.015,00
							TUB Y 63 FPVC						50	230,00	Connection socket in PE electro-welded to the tank with flanged connection in PVC.
							TUB Y 75 FPVC						65	250,00	
							TUB Y 90 FPVC						80	270,00	
							TUB Y 110 FPVC						100	305,00	
							TUB Y 125 FPVC						125	345,00	
							TUB Y 160 FPVC						150	415,00	
							TUB Y 200 FPVC						200	635,00	
							TUB Y 250 FPVC						250	985,00	





X	X	X	X	GRA	Anti-intrusion grid		GRA Y 40-80 AC		400	800			Shaped rectangular anti-intrusion grid.	295,00
							GRA Y 40-80 IX		400	800				440,00
X	X	X	X	GRI	Anti-intrusion grid		GRI Y 600				600		Circular anti-intrusion grid ø 600 mm.	90,00
X	X	X	X	TUB GRN	Overflow pipe PVC male	PVC 	TUB Y 125 GRN					125	Pipe socket in PVC male connected to tanks/tank with lip gasket	50,00
							TUB Y 160 GRN					150		65,00
							TUB Y 200 GRN					200		75,00
							TUB Y 250 GRN					250		110,00
		X		TDC	Decanter pipe Bioblu		TDC X 125		160	320	1.800	125	Rotomoulded pipe in polyethylene to be inserted at the inlet of rainwater recovery plants in order to avoid hydraulic turbulence inside the tanks	90,00
X				KIT AIR	Valved fitting air-lift		KIT Y AIR					1" 1/4	Fitting with double ball valve for regulating the air flow sent to biological plants equipped with diffusers and recirculation air-lift	250,00
X	X	X		GRN	Lip gasket		GRN Y 50					50	Gasket Ø 50 mm	10,00
							GRN Y 63					63	Gasket Ø 63 mm	10,00
							GRN Y 80					80	Gasket Ø 80 mm	10,00
							GRN Y 100					100	Gasket Ø 100	15,00
							GRN Y 110					110	Gasket Ø 110 mm	15,00
							GRN Y 125					125	Gasket Ø 125 mm	20,00
							GRN Y 160					160	Gasket in EPDM Ø 160 mm	30,00
							GRN Y 200					200	Gasket in EDPM Ø 200 mm	35,00
							GRN Y 250					250	Gasket Ø 250 mm	40,00
X	X	X	X	RPP PP	Bulkhead fitting in polypropylene Insertion from outside		RPP Y 034 PP					3/4"	Threaded bulkhead fitting male PP 3/4'	15,00
							RPP Y 100 PP					1"	Threaded bulkhead fitting male PP 1"	20,00
							RPP Y 114 PP					1.1/4"	Threaded bulkhead fitting male PP 1"1/4	25,00
							RPP Y 112 PP					1.1/2"	Threaded bulkhead fitting male PP 1"1/2	30,00
							RPP Y 200 PP					2"	Threaded bulkhead fitting male PP 2"	35,00

use				group code	group description	article		dimensional characteristics				description	€			
biological	rainwater treatment	water recovery	hydraulics			icon	code	vol.	Le	W	h			Ø DN		
								liters		mm				mm		
X	X	X	X	RPP PO	Transition fitting PE/Brass		RPP Y 020 PO					20 / 1/2"	Transition fitting made by socket in polyethylene welded to the tank and male threaded edge in brass.	25,00		
							RPP Y 025 PO								25 / 3/4"	30,00
							RPP Y 032 PO								32 / 1"	35,00
							RPP Y 040 PO								40 / 1 1/4"	50,00
							RPP Y 050 PO								50 / 1 1/2"	60,00
							RPP Y 063 PO								63 / 2"	75,00
X	X	X	X	RPP PX	Transition fitting PE/Stainless steel		RPP Y 020 PX					20 / 1/2"	Transition fitting made by socket in polyethylene welded to the tank and male threaded edge in stainless steel AISI 316.	40,00		
							RPP Y 025 PX								25 / 3/4"	60,00
							RPP Y 032 PX								32 / 1"	75,00
							RPP Y 040 PX								40 / 1 1/4"	115,00
							RPP Y 050 PX								50 / 1 1/2"	135,00
							RPP Y 063 PX								63 / 2"	140,00
	X			VLC	Clapet valve		VLC Y 125					125	Clapet valve to be inserted on PVC pipe made by frame and stainless steel rod and plastic float for closing first rain tank supply	530,00		
							VLC Y 160								160	570,00
							VLC Y 200								200	650,00
							VLC Y 250								250	720,00
							VLC Y 315								315	790,00
			X	SAR	Cast iron gate valve		SAR Y GHI DN50					50	Flanged flat body gate valve in cast iron complete with hand wheel in cast iron	255,00		
							SAR Y GHI DN65								65	315,00
							SAR Y GHI DN80								80	390,00
							SAR Y GHI DN100								100	475,00
							SAR Y GHI DN150								150	815,00

		X	X	VAL	Float valve		VAL A 34					3/4"	Float valve for closing aqueduct supply in polypropylene	50,00
							VAL A 50					2"	Float valve for closing water supply from aqueduct with double ball.	345,00
			X	VRF	Ball check valve		VRF Y GHI 025					1"	Ball check valve in cast iron threaded or flanged for installation on pump delivery pipes	130,00
						VRF Y GHI 032						1" 1/4		130,00
						VRF Y GHI 040						1" 1/2		145,00
						VRF Y GHI 050						2"		165,00
						VRF Y GHI DN50						50		285,00
						VRF Y GHI DN65						65		365,00
						VRF Y GHI DN80						80		435,00
						VRF Y GHI DN100						100		560,00
						VRF Y GHI DN150						150		1.110,00
X				CDR	Filling bodies		CDR Y 120	120		200	38	Cylindrical shaped filling bodies with high specific surface usable on biological purification tanks for the adhesion and growth of the biomass. Specific surface in m ² /m ³ is indicated in column Vol. Price is considered €/m ³	525,00	
						CDR Y 500	500		25	10			3.670,00	
	X			CCO	Coalescence cartridge		CCO X C 090		350	350	740	Cartridge realized with sponge in high specific density polyurethane, wrapped in threaded PE spool at the base for insertion on the outlet siphon, designed for housing the float shutter	285,00	
						CCO X C 115		350	350	1.020			315,00	
						CCO X C 135		350	350	1.315			345,00	
						CCO X CB 130		366	366	670			390,00	
						CCO X CB 185		435	435	950			495,00	
	X			OTG	Float shutter		OTG X C080			350	125	Float shutter for automatic closure of oil separators outlet pipes in case of excessive layer of oil inside of it.	45,00	
						OTG X CB 130				350	315		145,00	
						OTG X CB 185				620	400		175,00	
						OTG X M 400				200	400		420,00	
						OTG X MB 800				200	800		490,00	
	X			SPU	Polyurethane filter for coalescence cartridge		SPU Y 340		1.000	1.000	25	Polyurethane foam sheet used to make coalescence filters	160,00	

use				group code	group description	article		dimensional characteristics					description	€
biological	rainwater treatment	water recovery	hydraulics			icon	code	vol.	Le	W	h	Ø DN		
								liters		mm		mm		
	X			PLM	Lamella Pack		PLM Y 245		1.800	300			Coalescing filter obtained from the assembly of PVC sheets accurately shaped by thermoforming. The pack is characterized by an alveolar structure and a high specific surface.	190,00
		X		FIL FA	Self-cleaning Leaf Filter		FIF X 090		840	400			Self-cleaning leaf filter complete with manhole B125 in polymeric material	790,00
		X		FIL FM	Manual Leaf Filter		FIF X 100		600	600	850		Leaf filter on octagonal shaft with removable mesh basket in PVC.	520,00
X	X			SKYD RIM	Manual sand carbon filter plant in Skid		SKYD Y 020 RIM		1.150	580	1.790		Pressure filtration plant with manual filters backwash, composed by sand filter and active carbon filter, assembled on stainless steel skid.	7.760,00
							SKYD Y 040 RIM		1.150	580	1.790			8.705,00
							SKYD Y 060 RIM		1.350	760	2.060			13.915,00
							SKYD Y 100 RIM		1.500	890	2.060			16.465,00
							SKYD Y 230 RIM		2.800	1.300	2.200			27.830,00
X		X		MEM	Ultrafiltration membrane		MEM Y 035		3.490	3.490			Membrane ultrafiltration module for separating the biomass. The membrane can be used as refinement treatment	2.010,00
							MEM Y 080		3.490	3.490				2.945,00
							MEM Y 160		4.790	4.430				6.565,00
X				SOF	Blower		SOF MEM 035 M						Membrane blower for air insufflation inside aerobic biological plants.	420,00
							SOF MEM 048 M							545,00
							SOF MEM 050 M							650,00
							SOF MEM 115 M						Membrane linear compressor.	1.490,00
							SOF CAN 110 M						Lateral channel blower for air insufflation inside biological plants.	2.625,00
							SOF CAN 220 T							2.700,00
X				RIC	Recirculation pump Complete kit		KIT Z RIC037 MM					Pump for sewage for sludge recirculation 0,37 kW single-phase, complete with delivery pipe and check valve 1"1/4..	835,00	
X				EQU	Equalization pump Complete kit		KIT Z EQU037					Pump for sewage for regulating the flow rate single-phase power 0,37 kW complete with delivery pipe 1"1/4 with valved cut for regulating the flow rate.	910,00	
X				MIS	Mixer Complete kit		MIS Z 055					Submersible mixer with self-cleaning propeller with two blades, three-phase motor power 0,55 kW complete with anchoring device to the tank.	5.555,00	

	X			SEN	Rain sensor		SENPI							Heated capacitive rain sensor including power supply 12v to connect to first-rain panel	445,00
	X			SLO	Oil level sensor		SLO Z 003		230	250		300		Oil level sensor composed of 2 leveling floats contact with adjustable rods for oil level signalling to be combined with alarm panel QE ALL Z3 SM (not included).	320,00
	X			SLA	Oil level sensor Atex		SLA Z ATEX							Oil level sensor pursuant to ATEX for detecting oil on oil separators complete with electric control panel.	2.945,00
X				SLG	Greases level sensor		SLG Z 002							Greases level alarm device including control unit and capacitive type sensor (single-phase).	4.620,00
			X	SLV	Visual column water level indicator		SLV Y 001							Visual level indicator to be inserted outside the tanks	245,00
		X	X	INT GAL	Float switch		INT GAL P INT GAL G		70 81			172 109		Float level switch complete with cable and counterweight.	30,00 125,00
		X		PRF	Flow pressure switch		PRF Z 080					1" 1/4		Single-phase electronic pressure flow switch for direct control of electric pumps and control against dry running	195,00
		X		CEN IR	Irrigation control unit		CEN Y IR		580	300	600	1"		Pre-assembled kit for water replenishing from aqueduct for recovery systems complete with solenoid valve, with float switch and connection panel	1.985,00
		X		CEN ID	Hydraulic control unit		CEN Y ID		580	300	600	1"		Control unit for rainwater recovery system type HYDRAULIC including pressure switch, expansion vessel, non-return valve, electric panel and frame in stainless steel for wall fixing	3.035,00
		X		KIT ACQ	Aqueduct replenishment kit		KIT ACQ 220							Pre-assembled kit for water replenishing from aqueduct for recovery systems complete with solenoid valve, with float switch and connection panel	525,00
X				QE AIR	Biological Purification Panel		QAIR Z 1CM		185	190	110			Electric panel for single-phase air blower with timer.	480,00
							QAIR Z 2CM		300	400	200			Electromechanical panel for the control of the electromechanical component of biological purification plants with time switches s and thermal protection system for N. 2 single-phase users.	1.870,00
							QAIR Z 3CT		300	400	200			Electromechanical panel for the command of 1 three-phase blower 2.2 kW and 2 single-phase pumps 0.37 kW. For biological purification plants.	2.400,00
							QAIR Z 2TIMER							Electromechanical panel for the control of 2 single-phase membrane compressors with digital timer ON/OFF for plants type DSS and DST.	570,00

use					group code	group description	article		dimensional characteristics					description	€		
biological	rainwater treatment	water recovery		hydraulics			icon	code	vol.	Le	W	h	Ø DN				
									liters		mm		mm				
	X				PLM	Lamella Pack		PLM Y 245		1.800	300				Coalescing filter obtained from the assembly of PVC sheets accurately shaped by thermoforming. The pack is characterized by an alveolar structure and a high specific surface	190,00	
X					ATT	Biological activators and freeze-dried bacteria		ATT Y TBS							Biological activator of natural origin for inoculum and activation of biological treatment plants.	30,00	
X				STAR SINK												Additive in bars consisting of natural microorganisms for the degradation of greases and organic substances that settle in kitchen drains and in grease separators.	20,00
X	X			ATT Y SCH												Additive for foam and surfactant removal. Particularly suitable as anti-foam on wastewater treatment plants from car wash.	80,00
X					RPH	pH controller Complete kit		KIT ZR PH022							Kit for pH regulation including detection sensor, automatic dosing pump and tank 50 litres for reagent containment	3.075,00	
X					POM D	Dosing pump Complete kit		POM Z D022	50						Dosing pump with manual regulation of the flow rate complete with tank 100 litres for reagent storage	1.065,00	
X					TCL	Chlorine tablets		TCL Y 200							Chlorine-based tablet for the disinfection of the outgoing waste water in biological plants	20,00	
		X			LUV	UV Lamp		LUV Z 045							UV lamp for water disinfection complete with power supply. Cover in stainless steel AISI 304 and connections 1" male	1.140,00	







Zona Industriale, 64030
Basciano (TE)
t +39 **0861 650109**
info@di-camillo.com
www.di-camillo.com

This catalog and all its technical data are the property of DI CAMILLO SERBATOI,
its reproduction is strictly forbidden.
DI CAMILLO SERBATOI reserves the right to make changes or improvements at
any time without any notice.